

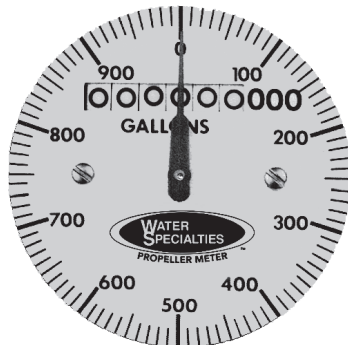

**MODEL MLT1X**  
 150 psi REPLACEMENT METER HEAD ASSEMBLY  
 SEALED METER MECHANISM - MAGNETIC DRIVE  
 SEALED TOTALIZER  
 SIZES 6" thru 72"

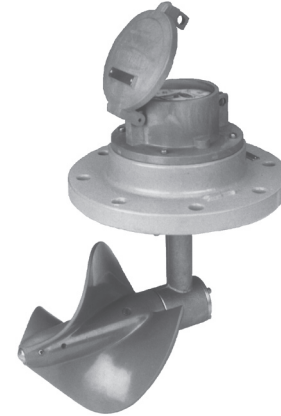

TOTALIZER

**DESCRIPTION**

**MODEL MLT1X METER HEAD ASSEMBLIES** are manufactured to the highest standards. Materials used on all meters and flow ranges for the low velocity meter meet or exceed AWWA standard C704-02. The bolt-on design permits use in a wide range of existing applications with up to 150 psi working pressure. It is necessary, upon ordering, to furnish the I.D. dimension of the pipe the meter is to be mounted on for calibration purposes, and the saddle dimensions from the back of the data sheet. It may be necessary to modify or remove the existing straightening vanes to allow proper clearance for Water Specialties three bladed propeller (see propeller dimension on back of data sheet).

**INSTALLATION** is made by bolting the meter head assembly to the existing saddle or meter tube. The meter can be installed in any of the following positions; vertically, horizontally or inclined on suction or discharge lines. The meter must have a full flow of liquid for proper accuracy. Fully opened gate valves, fittings or other obstructions that tend to set up flow disturbances should be a minimum of ten pipe diameters upstream and two pipe diameters downstream from the meter. Installations with less than ten pipe diameters of straight pipe require straightening vanes. Meters with straightening vanes require at least five pipe diameters upstream and two pipe diameters downstream of the meter.

**PROPELLER** is magnetically coupled with the drive mechanism through the sealed oil filled gearbox. This completely eliminates water entering the meter assembly, as well as the need for any packing gland. The propeller is a conical shaped three bladed propeller, injection molded of thermoplastic material resistant to normal water corrosion and deformity due to high flow velocities.

**BEARING** in 6" thru 54" propellers is a water lubricated ceramic sleeve and spindle bearing system with a ceramic/stainless steel spindle. Dual ceramic thrust bearings, standard on all 6" - 54" meters, handle flows in both forward and reverse directions. The 60" thru 72" propeller bearings are sealed stainless steel ball bearings that ride on a stainless steel spindle. The bearing design promotes extended periods of maintenance free propeller operation. Bearings within the sealed meter mechanism are shielded precision stainless steel bearings and are factory lubricated for the life of the meter.

**TOTALIZER** is o-ring sealed and magnetically coupled with the driving mechanism, and features a six digit totalizer with a full 3" diameter, 100 division, center sweep dial that permits extremely accurate readings for timing purposes in determining flow rates. The totalizer dial can be furnished in gallons, cubic feet, acre feet, or any standard liquid measuring units. The bonnet, with padlock hasp, can be positioned in four different directions for the easiest possible reading when the meters are mounted in unusual positions.

**CHANGE GEARS** may be easily exchanged in the field when changing the dial, or when recalibrating for different pipe sizes. It is not necessary to remove pressure from the line for these changes.

**O-RING SEALS** are used at the meter head and all points where seals are required, making the meter mechanism completely immune to any of the corrosive effects of atmospheric moisture or the liquids measured by the meter assembly.

**SPECIFICATIONS**

<b>ACCURACY</b>	Plus or minus 2% of actual flow within the range specified for each meter size.
<b>PRESSURE RANGE</b>	Up to 150 PSI maximum working pressure.
<b>TEMPERATURE RANGE</b>	140° F Maximum. Consult factory for special construction for higher temperatures.
<b>MINIMUM FLOWS</b>	As shown for each meter size and construction are required for accurate registration. See flow chart. NOTE: Minimum flow will be higher when auxiliary equipment is added.
<b>MAXIMUM FLOWS</b>	As shown for each meter size and construction are rated for continuous operation. See flow chart.
<b>INTERMITTENT FLOWS</b>	As shown for each meter size are rated for 10% to 15% of the total time the meter is operating. Consult factory for High Velocity construction when intermittent flows are higher than shown on flow chart and/or when longer operating periods are required.
<b>MATERIALS</b>	used in construction are chosen to minimize the corrosive effects of the liquids measured by the meter assembly. <b>MAGNETS</b> - permanent ceramic type <b>INTERIOR BEARINGS</b> - shielded stainless steel <b>PROPELLER BEARING</b> - ceramic sleeve type (6"-54") or sealed stainless steel ball type (60"-72") <b>PROPELLER SPINDLE</b> - ceramic sleeve/stainless steel (6"-54") or stainless steel (60"-72") <b>PROPELLER</b> - injection molded thermoplastic <b>GEARBOX</b> - cast bronze (6"-54") <b>SEPARATOR</b> - stainless steel <b>SHAFTS</b> - stainless steel <b>METER HEAD BOLTS</b> - stainless steel (6"-20"), plated steel (24"-72") <b>METER HEAD</b> - cast iron or fabricated steel, fusion epoxy coated.
<b>OPTIONAL EQUIPMENT</b>	Totalizer Extensions and a wide range of controls and instruments for indicating, totalizing, and recording flow data for each meter. Special constructions and materials are available upon request.
<b>ORDERING INFO</b>	Must be specified by the customer and includes: Minimum & maximum flow ranges; Temperature of meter environment; Totalizer dial units; Type of materials and construction; Optional equipment desired; I.D. of pipe; Saddle dimensions (from back).

### MODEL MLT1X

150 psi REPLACEMENT METER HEAD ASSEMBLY  
 SEALED METER MECHANISM - MAGNETIC DRIVE  
 SEALED TOTALIZER  
 SIZES 6" thru 72"

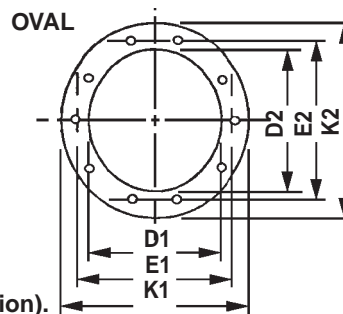
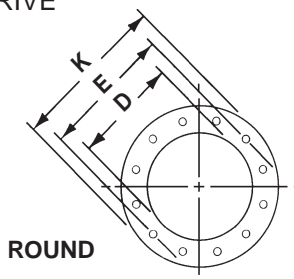
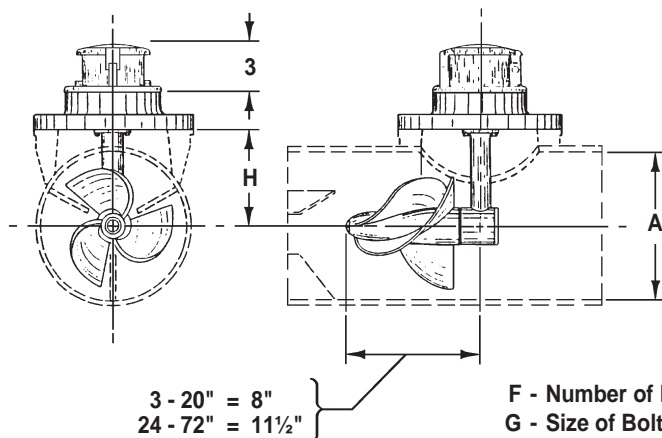

F - Number of Bolts  
 G - Size of Bolts

**NOTE:** Existing straightening vanes may require modification or removal to allow proper clearance for Water Specialties three bladed propeller (see propeller dimension).

METER & PIPE SIZE	FLOW RANGES, GPM		DIMENSIONS (Customer Supplied Data)							EST SHIPPING WEIGHT POUNDS
	STANDARD CONSTRUCTION MIN. - MAX. - INT.	HIGH VELOCITY CONSTRUCTION MIN. - MAX.	A	(D1,D2) D	(E1,E2) E	F	G	H	K	
6	120-1200-1500	300-1500								35
8	150-1500-2000	400-2500								35
10	180-2000-3000	500-3500								45
12	200-3000-3500	800-5000								50
14	300-4000-4500	1000-6000								55
16	400-5000-6000	1200-7500								55
18	700-6000-7500	1500-9000								55
20	850-8000-9000	2000-12000								55
24	1000-10000-13500	3000-15000								190
30	1800-15000-21000	4000-25000								190
36	2000-20000-30000	5000-35000								190
42	3000-30000-40000	6000-50000								365
48	5500-35000-50000	7000-60000								365
54	6500-45000-55000	8000-65000								365
60	7500-60000-80000	10000-90000								365
66	8500-75000-95000	12000-105000								365
72	9500-90000-115000	15000-125000								365

Standard construction will be supplied for all main line meters unless special flow range, materials, or construction are required.



www.mccrometer.com

3255 WEST STETSON AVENUE • HEMET, CALIFORNIA 92545 USA  
 TEL: 951-652-6811 • FAX: 951-652-3078

Copyright © 2000-2007 McCrometer. All printed material should not be changed or altered without permission of McCrometer. The published technical data and instructions are subject to change without notice. Contact your McCrometer representative for current technical data and instructions.