



3-3519.090

Rev. D 5/05 English



SAFETY INSTRUCTIONS

1. The 3519 Flow Wet-Tap Valve may only be installed into, and removed from, non-pressurized systems (0 psig).
2. The pressure must be reduced to 25 psi when removing or installing the sensor and must maintain 25 psi or lower while the sensor is removed.
3. Stay clear of sensor stroke area and safety cable during sensor removal.
4. Confirm chemical compatibility before use.
5. Do not exceed maximum temperature/pressure specifications.
6. Wear safety goggles or faceshield during installation/service.
7. Do not alter product construction.

Failure to follow safety precautions may result in severe personal injury!

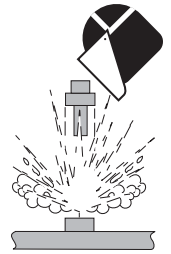

1. Specifications

Materials

- Body: PVC
- Ball seat: PTFE
- O-rings: FPM

Standards

- Manufactured under ISO 9001 and 14001

Fluid Conditions

Pressure/Temperature Ratings:

- 7 bar max. @ -18 to 20°C
(100 psi max. @ 0 to 68°F)
- 1.4 bar max. @ 66°C
(20 psi max. @ 150°F)

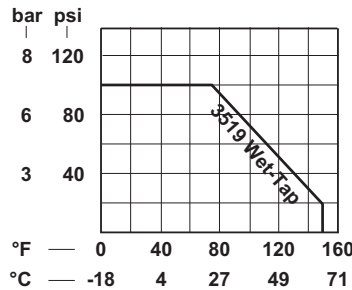

Dimensions

Total minimum clearance for sensor insertion and removal:

- 1/2 to 4 inch pipe: 737 mm (29 inches)
- 5 to 8 inch pipe: 762 mm (30 inches)
- 10 inch and up: 813 mm (32 inches)

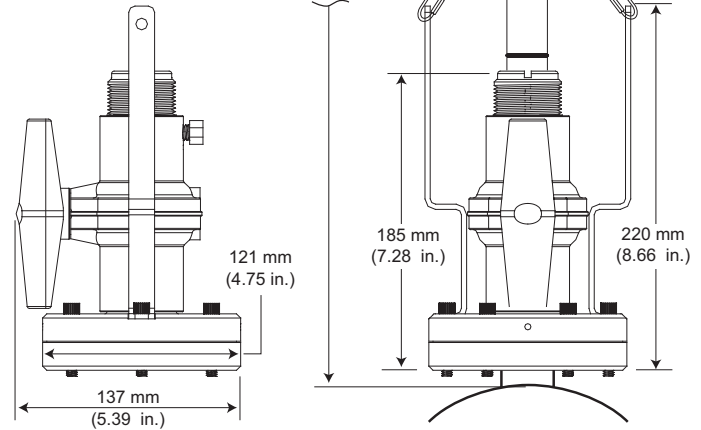





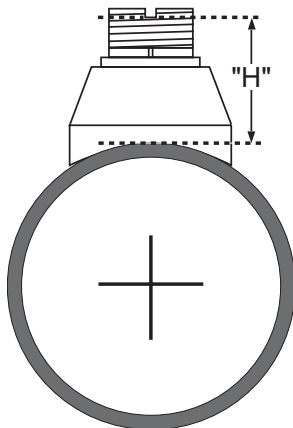





2. H-Dimensions

The plastic sensor insert in the Weldolet fitting **MUST** be removed before the welding process. When reinstalled, it is important that the insert be threaded to the proper height ("H" dimension).



Part Number	Carbon Steel		Part Number	Stainless Steel	
	"H" dimensions			"H" dimension	
	inches	mm		inches	mm
CS4W020	2.38	60.45	CR4W020	2.38	60.45
CS4W025	2.33	59.18	CR4W025	2.33	59.18
CS4W030	2.32	58.92	CR4W030	2.32	58.92
CS4W040	2.30	58.42	CR4W040	2.30	58.42
CS4W050	3.09	78.48	CR4W050	3.09	78.48
CS4W060	2.96	75.18	CR4W060	2.96	75.18
CS4W080	2.73	69.34	CR4W080	2.73	69.34
CS4W100	5.48	139.19	CR4W100	5.48	139.19
CS4W120	5.25	133.35	CR4W120	5.25	133.35
CS4W140	5.10	129.54			
CS4W160	4.85	123.19			
CS4W180	4.60	116.84			
CS4W200	4.38	111.25			
CS4W240	4.16	105.66			
CS4W360	4.10	104.14			

3. Signet Fittings

Type	Description	Type	Description
Plastic tees 	<ul style="list-style-type: none"> • 0.5 to 4 inch versions • PVC or CPVC 	Carbon steel & stainless steel threaded tees 	<ul style="list-style-type: none"> • 0.5 to 2 inch versions
PVC Glue-on Saddles 	<ul style="list-style-type: none"> • Available in 10 and 12 inch sizes only • Cut 2-1/2 inch hole in pipe • Weld in place using solvent cement 	Carbon steel & stainless steel Weld-on Weldolets 	<ul style="list-style-type: none"> • 2 to 4 inch, cut 1-7/16 inch hole in pipe • Over 4 inch, cut 2-1/4 inch hole in pipe • See section 4 below for details
PVC Saddles 	<ul style="list-style-type: none"> • 2 to 4 inch, cut 1-7/16 inch hole in pipe • 6 to 8 inch, cut 2-1/4 inch hole in pipe 	Metric PVC-U Saddle 	<ul style="list-style-type: none"> • For pipes DN 65 to 200 mm • Requires a 30 mm diam. hole in the pipe
PP Clamp-on Saddles 	<ul style="list-style-type: none"> • Available in 10 and 12 inch sizes only • Cut 2-1/4 inch hole in pipe 	Metric Wafer Fitting 	<ul style="list-style-type: none"> • For pipes DN 65 to 200 mm • PP or PVDF
Iron Strap-on saddles 	<ul style="list-style-type: none"> • 2 to 4 inch, cut 1-7/16 inch hole in pipe • Over 4 inch, cut 2-1/4 inch hole in pipe • Special order over 12 inch 	Metric Union Fitting 	<ul style="list-style-type: none"> • For pipes from DN 15 to 50 mm • PP or PVDF

Consult the Signet Measurement and instrumentation Catalog for a complete listing of installation fittings.

4. Wet-Tap Valve Installation

The Signet 3519 Flow Wet-Tap Assembly attaches directly to Signet installation fittings to enable flow sensor removal without system shutdown. It consists of a flange and support plate which thread onto the pipe fitting insert, and a PVC ball valve through which an extended length flow sensor is inserted into the pipe.



Caution: The 3519 Flow Wet-Tap Valve may only be installed into, and removed from, non-pressurized systems (0 psig).

Procedure

1. Remove six hex nuts and bolts from the Wet-Tap flange. Separate the support plate from the main assembly. Be sure that the Viton O-ring is properly seated in the support plate groove.
2. Apply sealant to the pipe fitting insert threads to prevent leaks. To eliminate any leakage, the valve can be sealed to the fitting using one of these two methods:
 1. Use a silicone RTV such as "GE Sealants and Adhesives Silicone II".
 2. Use a PVC cement such as Christy's "Red Hot Blue Glue" (for PVC fittings) or a similar PVC pipe cement.

NOTE: This will permanently bond the valve to the installation fitting and will not allow for errors in the installation process due to a quick drying period.

3. Screw support plate onto pipe fitting insert (O-ring side facing up). It must be threaded completely down until the notches at the top of the pipe fitting insert are exposed.
4. Mount the main Wet-Tap Assembly on the support plate. Make certain the alignment keys on the flange mate with the notches on the pipe fitting insert.
5. Loosen support plate (holding the main Wet-Tap Assembly in place) until it resists slightly. Loosen an additional 1/4-turn to seat O-ring.
6. Replace the six hex nuts and bolts to secure the Wet-Tap Assembly in place. Adjust the support plate position as necessary to align screws.
7. Check the pressure relief plug on Wet-Tap Assembly. It must be closed finger tight to prevent leaks.
8. Close ball valve by turning the handle to the fully closed position (parallel with pipe).

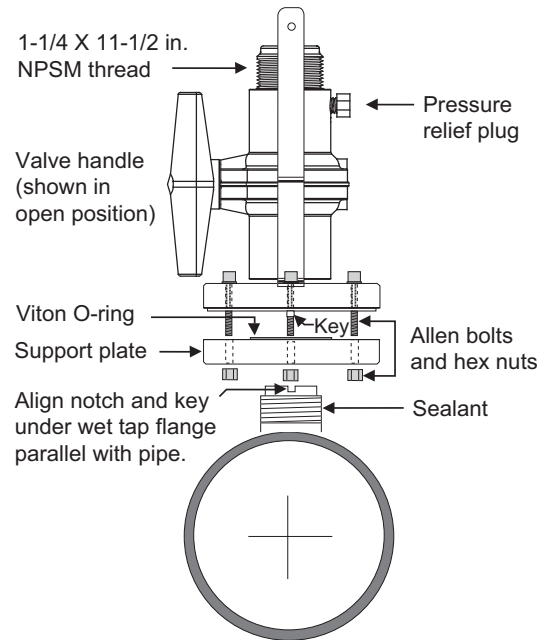

5. Flow Sensor Insertion/Removal

To insert the flow sensor:

1. Lubricate the sensor O-rings with a lubricant compatible with your process and the sensor materials of construction. Do not use petroleum based lubricants that will attack the o-rings.
2. Carefully insert the sensor into the 3519 valve assembly until the first two O-rings seat inside the bore. (Figure 1)
 - **Do not damage the rotor on closed ball valve.**
3. Using the clamps, attach the sensor safety cable to the 3519 assembly brackets (hand tighten only).
4. Pull the flow sensor upward to remove slack in the safety cables. (Figure 2)



Warning: Safety cables are factory installed at precise length. DO NOT attempt to service or replace safety cables.



Warning: System pressure must be 25 psi or less prior to sensor insertion or removal.



5. Open the ball valve. (Figure 2).
6. Push the flow sensor into the 3519 assembly with a twisting motion.
 - Turn the sensor so the arrows on the black conduit cap point in the direction of flow.
 - When properly aligned the sensor bale will be parallel with the pipe. (Figure 3)

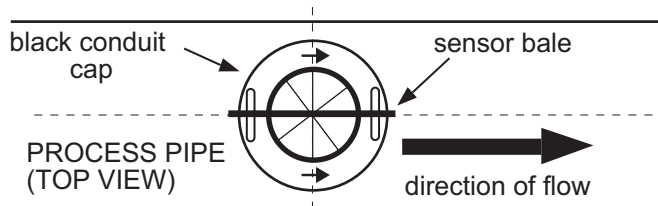

Figure 3

7. Align the tabs under the sensor cap with the notches on the fitting insert and tighten the sensor cap. (Figure 4)
 - **HAND TIGHTEN ONLY.** DO NOT use any tools that may damage plastic parts.

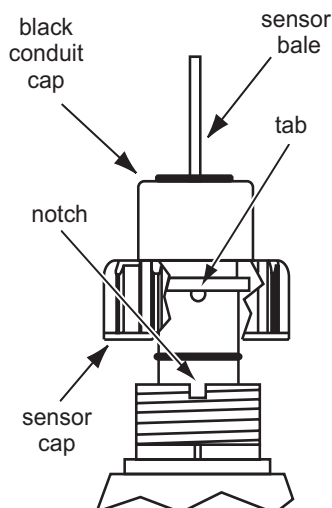

Figure 4

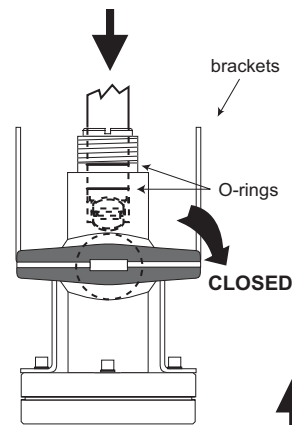

Figure 1

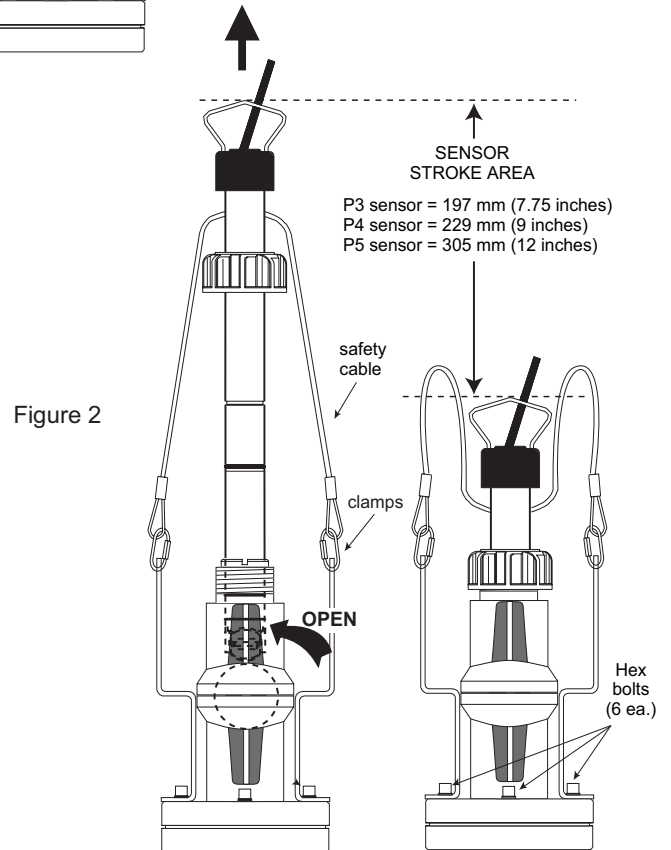

Figure 2

To remove the flow sensor:



Warning: System pressure must be 25 psi or less prior to flow sensor insertion or removal. Stay clear of sensor stroke area and safety cable during sensor removal.



Check the six (6) Hex bolts (Figure 2) prior to unscrewing the sensor cap. **If bolts are loose, tighten securely before proceeding.**

1. Unscrew the sensor cap. (DO NOT use any tools that may damage plastic parts.)
2. Carefully pull the flow sensor upward with a twisting motion until the safety lanyards are fully extended. (Figure 2)
3. Close the ball valve. (Figure 1)
4. Loosen the relief plug to depressurize the sensor area.
5. Disconnect the sensor safety cable clamps from the 3519 assembly brackets.
6. The sensor can now be safely removed.

6. Ordering information

Part Number	Code	Description
3-3519	159 000 757	PVC wet-tap valve (sensor not included)
P51530-P3	198 840 310	Polypro extended length paddlewheel sensor (0.5 to 4 in.)
P51530-P4	198 840 311	Polypro extended length paddlewheel sensor (5 to 8 in.)
P51530-P5	198 840 312	Polypro extended length paddlewheel sensor (10 to 36 in.)
3-2536-P3	159 000 758	Polypro extended length low flow paddlewheel sensor (0.5 to 4 in.)
3-2536-P4	159 000 759	Polypro extended length low flow paddlewheel sensor (5 to 8 in.)
3-2536-P5	159 000 760	Polypro extended length low flow paddlewheel sensor (10 to 36 in.)
3519/515-P3	159 000 819	Wet-tap assembly with 515 paddlewheel sensor (0.5 to 4 in.)
3519/515-P4	159 000 820	Wet-tap assembly with 515 paddlewheel sensor (5 to 8 in.)
3519/515-P5	159 000 821	Wet-tap assembly with 515 paddlewheel sensor (10 to 36 in.)
3519/2536-P3	159 000 822	Wet-tap assembly with 2536 low flow sensor (0.5 to 4 in.)
3519/2536-P4	159 000 823	Wet-tap assembly with 2536 low flow sensor (5 to 8 in.)
3519/2536-P5	159 000 824	Wet-tap assembly with 2536 low flow sensor (10 to 36 in.)



George Fischer Signet, Inc., 3401 Aerojet Avenue, El Monte, CA 91731-2882 U.S.A. • Tel. (626) 571-2770 • Fax (626) 573-2057
For Worldwide Sales and Service, visit our website: www.gfsignet.com • Or call (in the U.S.): (800) 854-4090

