

# WMX-SERIES

*Seametrics*

## MUNICIPAL/INDUSTRIAL MAGMETER INSTRUCTIONS



WMX-SERIES MUNICIPAL/INDUSTRIAL MAGMETER INSTRUCTIONS

**ISO** 9001:2008  
CERTIFIED



## TABLE OF CONTENTS

---

### **General Information**

General Information, Features ..... Page 1

### **Specifications**

Specifications, Flow Range ..... Page 2

### **Installation and Grounding**

Positioning the Meter, Straight Pipe Recommendations, Full Pipe Recommendations, Fittings,  
Calibration, Chemical Injection, Metal Pipe Installations, Plastic Pipe Installations ..... Page 3

**Straight Pipe Recommendations** ..... Page 4

**Full Pipe Recommendations** ..... Page 5

### **Inputs/Outputs and Operation**

Power, Pulse Output, High Frequency, K-Factor, Display Reading ..... Page 6

### **Connections Diagrams**

AO55/WMX101, FT420/WMX101, DL75 or DL76/WMX101 ..... Page 7

### **Troubleshooting**

Problem, Probable Cause, Things to Try ..... Page 8

## TABLES, DIAGRAMS & CHARTS

---

Features ..... Page 1

Specifications ..... Page 2

Flow Range ..... Page 2

Metal Pipe Installation, Plastic Pipe Installation ..... Page 3

Straight Pipe Recommendations ..... Page 4

Full Pipe Recommendations ..... Page 5

High Frequency Output ..... Page 6

Display Readings ..... Page 6

Connections Diagrams ..... Page 7

Troubleshooting ..... Page 8

## GENERAL INFORMATION

The **WMX-Series** are flanged electromagnetic flowmeters for use in 4" to 10" pipe in municipal or industrial water and wastewater applications where propeller meters have typically been used in the past. Because the WMX has no moving parts and has electrodes designed to discourage fouling, this magmeter performs well and requires much less frequent maintenance in applications where debris or sand would impede propeller meters. There is no rotor to stop turning or bearings to wear out. Minimal straight pipe requirements allow WMX-Series meters to be used in piping configurations where there is little space between the meter and an elbow.

In chemical injection applications, the meter should be placed upstream of the injection line or far enough downstream for thorough mixing to occur before the meter.

Rate and total indication are standard on both models. Flow measurement units are customer-selected and factory-set and can only be changed in the field by an authorized Seametrics dealer.

The **WMX101** is externally powered with 7-26 Vdc at 30 mA max (see WARNING on Wiring Diagrams). Two Lithium 3.6V "AA" batteries provide backup during power failures, allowing the meter to seamlessly continue recording flow rate and total for the duration of the outage. Under intermittent use, the battery life is approximately 10 years.

The 20-foot power cable also provides pulse output for use with a variety of Seametrics and other displays and controls for remote reading, data logging, pulse-to-analog conversion, and telemetry applications. Pulse rate is customer-selected and factory-set and can only be changed in the field by an authorized Seametrics dealer. Default is high frequency for use with 4-20 mA signal conversion devices.

The **WMX104** is a battery-operated unit for use when no additional input or output is required. The Lithium 3.6V "D" batteries are replaceable with an approximate 1-year life under continuous use, or more, depending on the duty cycle. An optional cable can be installed post-factory if power or pulse output is needed for changing applications.

## FEATURES

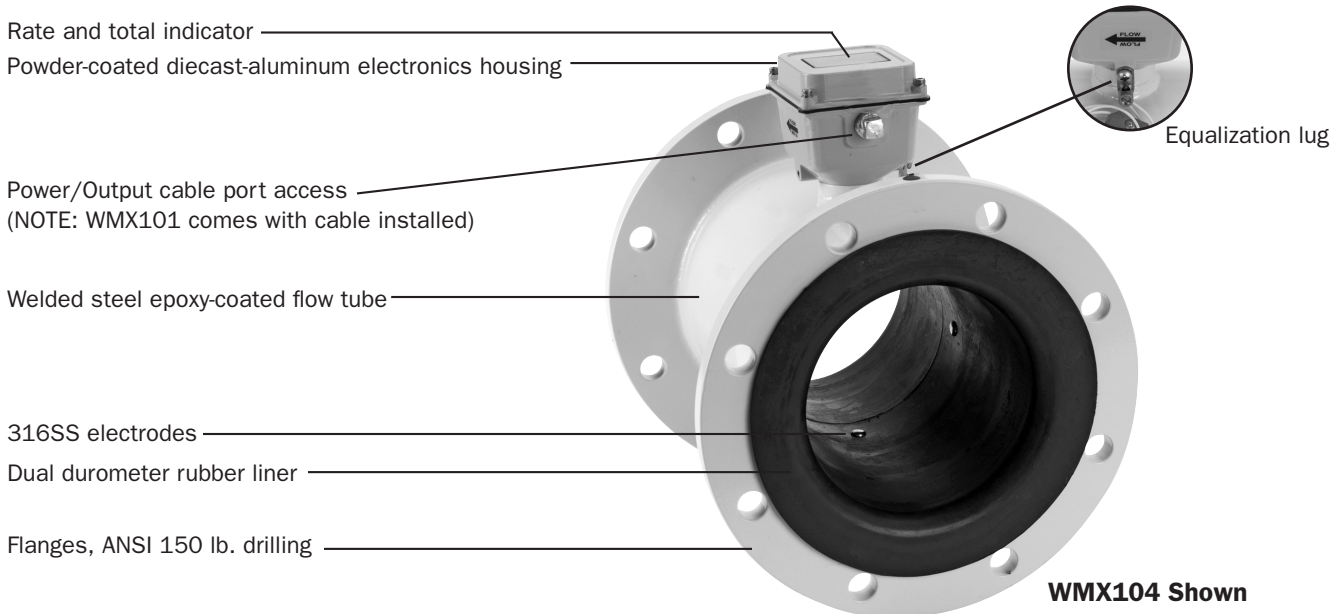

## SPECIFICATIONS

### SPECIFICATIONS\*

<b>Pipe Sizes</b>	4", 6", 8", 10"						
<b>Flanges</b>	ANSI 150 lb. drilling						
<b>Pressure</b>	150 psi (10.3 bar) working pressure						
<b>Temperature</b>	<b>Operating</b>	10° to 130° F (-12° to 54° C)					
	<b>Non-Operating</b>	-40° to 158° F (-40° to 70° C)					
<b>Accuracy</b>	+/-1% of reading from 10% to 100% of reading						
	+/-2% of reading from cutoff to 10% of reading						
<b>Materials</b>	<b>Body</b>	Welded steel, epoxy-coated					
	<b>Liner</b>	Dual durometer rubber					
	<b>Electronics Housing</b>	Diecast aluminum, powder-coated					
	<b>Electrodes</b>	316 stainless steel					
<b>Display</b>	<b>Rate</b>					<b>Total</b>	
	<b>Digits</b>	5				8	
	<b>Units*</b>	Gallon/Minute, Liter/Minute, Liter/Second, Cubic Feet/Minute, Cubic Meter/Hour, Million Gallon/Day, Mega Liter/Day				Gallon, Gallon x 1000, Liter, Liter x 1000, Mega Liter, Cubic Meter, Cubic Meter x 1000, Cubic Feet, Cubic Feet x 1000	
<b>Power</b>	<b>WMX101:</b> 7-26 Vdc at 30 mA max, with auxiliary battery for continuous operation during power failures NOTE: Using an unregulated power supply >18 Vdc may damage the meter due to AC line input voltage fluctuation						
	<b>WMX104:</b> 2 Lithium 3.6V "D" batteries, replaceable, 1 year life under continuous use						
<b>Pulse Output</b>	<b>Signal</b>	<b>WMX101:</b> Current sinking pulse, opto-isolated, 30 Vdc at 10 mA max					
		<b>WMX104:</b> Pulse output available only with addition of post-factory output cable					
	<b>Pulse Rates</b>	High Frequency (default); 10 units/pulse; 100 units/pulse; 1000 units/pulse					
	<b>High Frequency (pulse/gal)</b>	<b>4"</b>	<b>6"</b>	<b>8"</b>	<b>10"</b>		
<b>Conductivity</b>	>20 microSiemens						
<b>Empty Pipe Detection</b>	Hardware/software, conductivity-based						
<b>Environmental</b>	NEMA 4X						

\*Specifications subject to change. Please consult our website for the most current data ([www.seametrics.com](http://www.seametrics.com)).

### FLOW RANGE

	4"		6"		8"		10"	
	Gal/Min	Liter/Sec	Gal/Min	Liter/Sec	Gal/Min	Liter/Sec	Gal/Min	Liter/Sec
<b>Minimum</b>	12	.75	32	2	60	3.8	95	6
<b>Maximum</b>	500	31.5	1,200	75.7	2,200	138.8	3,500	220.8

## INSTALLATION and GROUNDING

### INSTALLATION



**Caution:** These flow sensors are not recommended where installation fault may expose the flow sensor to boiler pressure and temperature. Maximum recommended temperature is 130° F.

**Positioning the Meter.** These meters can be installed horizontally, vertically, and in any radial position.

**Straight Pipe Recommendations.** As with most flow meters, the WMX requires some straight pipe before and/or after the meter for best accuracy. However, the ability of electromagnetic meters to average the flow across the entire pipe allows for shorter straight pipe recommendations than most mechanical meters (see page 4).

**Full Pipe Recommendations.** All magmeters require a method for determining that the pipe is empty, to prevent false reading. This meter is designed to go to zero reading if one or more electrodes is exposed. For highest accuracy, install the meter so that the pipe will be full when there is flow. If air bubbles may be present in the pipe or sludge accumulation is an issue, rotate the meter by one flange hole to position the control housing at a 45° angle. See Full Pipe diagrams on page 5.

**Fittings.** The WMX flanges have standard ANSI 150 lb. drilling and mate with any other ANSI 150 lb. flange.

**Calibration.** The WMX is factory-calibrated and will not require any form of field calibration.

**Chemical Injection.** When any magmeter, by any manufacturer, is used in a chemical injection application, the chemical injection point must be placed downstream of the magmeter OR far enough upstream for complete mixing to occur before the fluid reaches the meter. When unmixed chemical alternates with water passing through the meter, the rapid changes in conductivity may cause sudden spikes and drops in the meter's reading, resulting in inaccurate measurement. The magmeter will restabilize, however, with a steady flow of fluid of uniform conductivity.



**Caution:** In chemical injection applications, install chemical injection point downstream of magmeter, or far enough upstream to allow complete mixing of fluids before the meter.

### EQUALIZATION AND GROUNDING

**Metal Pipe Installations.** To equalize the electrical potential of the fluid, the WMX meter, and the surrounding pipe, secure the flange plates (factory-installed on the equalization lug) to both pipe flanges at one of the bolt holes, as shown below. Be sure the lockwasher fits between the pipe flange and the flange plate.

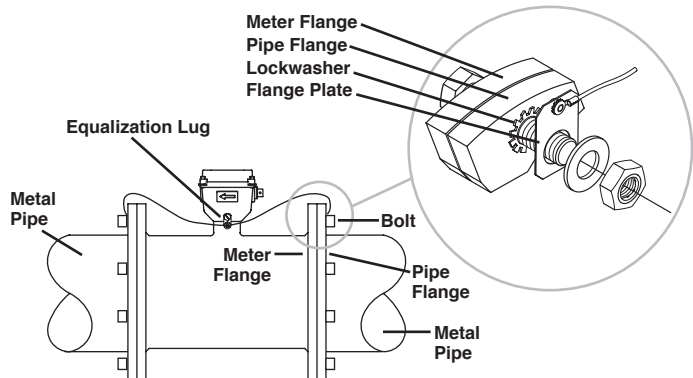

**Equalization Diagram**

Run wire from equalization lug to both pipe flanges; secure flange plates under bolt heads as shown.



**WARNING: ELECTRICAL SHOCK HAZARD** When the meter is externally AC powered (WMX101 or adapted 104), the piping system must be grounded to meet national and local electrical safety codes. Failure to do so can result in electrocution.

**Plastic Pipe Installations.** When the WMX is installed in a plastic piping system, it is not necessary to use the equalization straps, but very important to ground the meter to avoid electrical shock hazard and electrostatic interference with meter function.

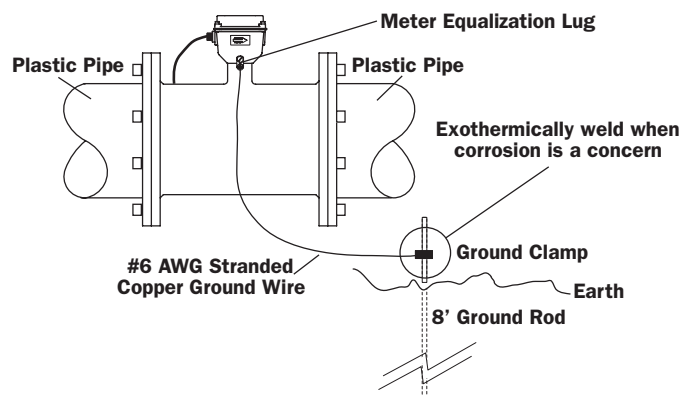

# STRAIGHT PIPE RECOMMENDATIONS

(X = diameter)

Reduced Pipe

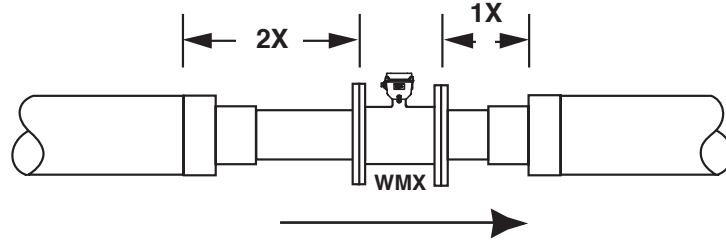

Two Elbows In Plane

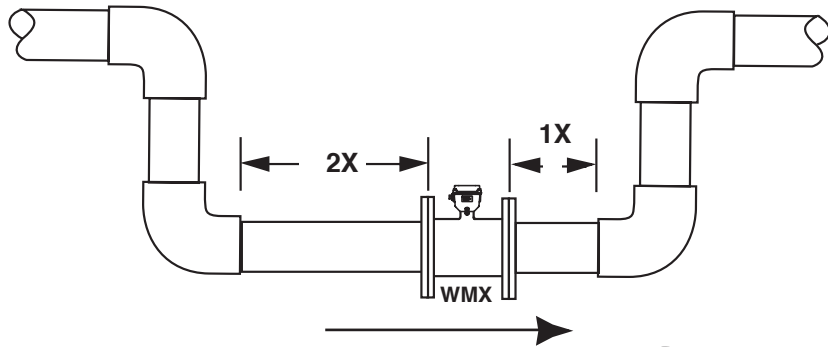

Two Elbows, Out Of Plane

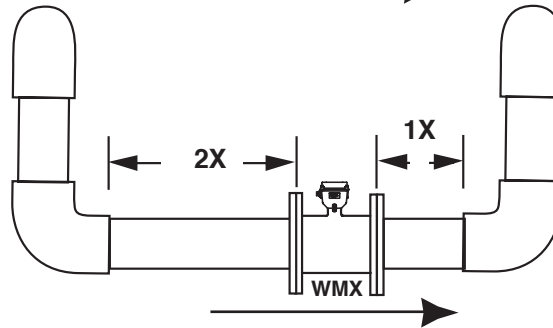

Expanded Pipe

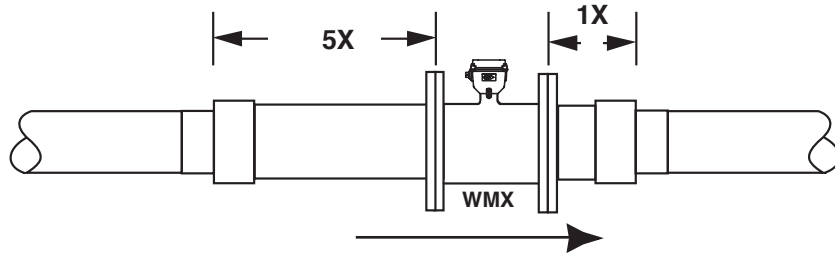

Swirling Flow  
Propeller Meter

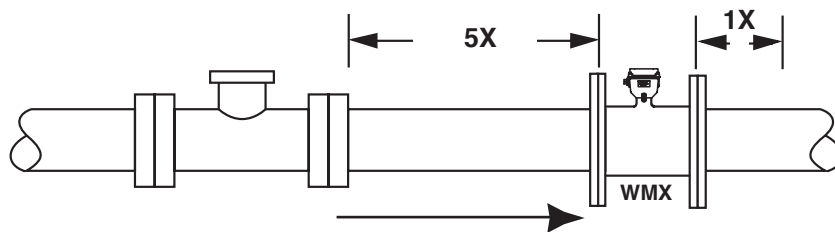

Swirling Flow  
Partially Open  
Butterfly Valve

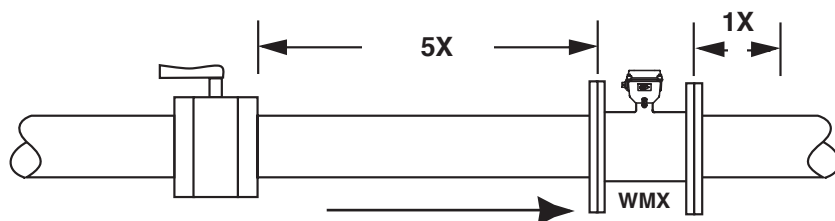

**FULL PIPE RECOMMENDATIONS**

**Recommended:**  
Keep pipe full at meter for accuracy

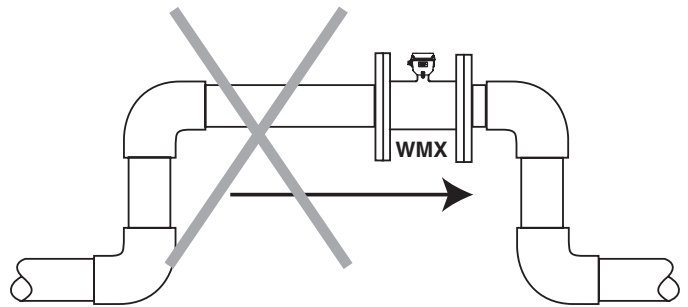
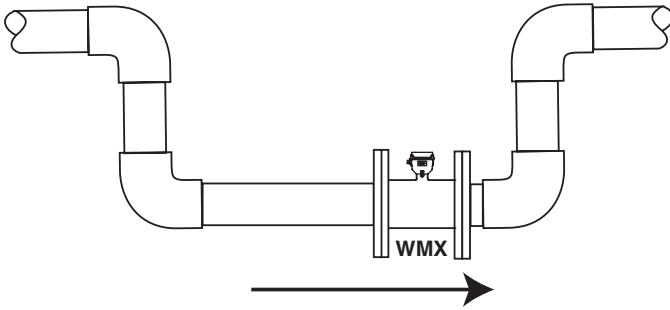

**Not Ideal:**  
Allows air pockets to form at meter

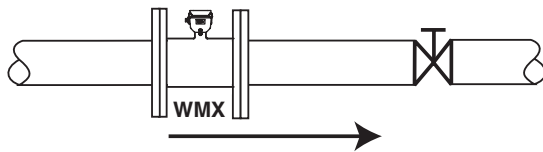

**Recommended:**  
Keeps pipe full at meter for accuracy

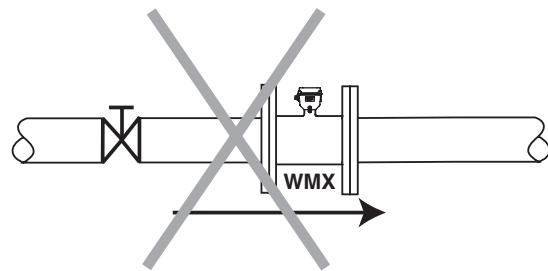

**Not Ideal:**  
Post-valve cavitation can create air pocket

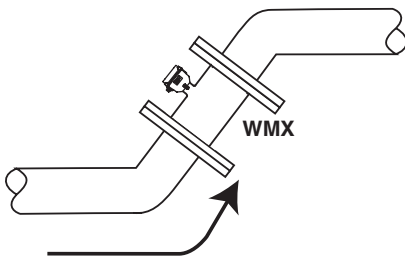

**Recommended:**  
Allows air to bleed off

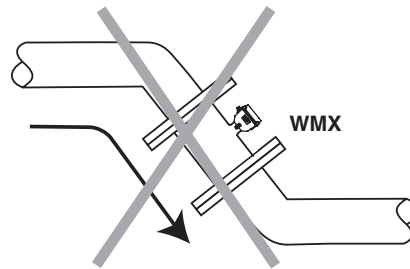

**Not Ideal:**  
Air can be trapped

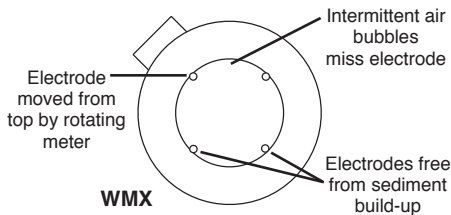

**Recommended:**  
Improved accuracy results from unimpeded electrodes

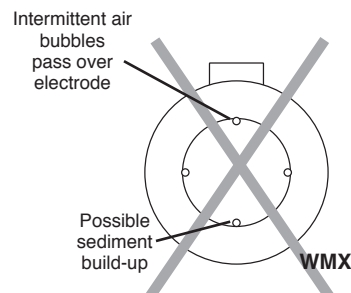

**Not Ideal:**  
Air bubbles and sediment on the electrodes can affect accuracy

## INPUTS/OUTPUTS and OPERATION

### WMX101

**External Power (WMX101).** The WMX101 operates on 7-26 Vdc at 30 mA max external power (see WARNING in wiring diagrams). The display reads “P” when external power is in use (see illustration below).

The Lithium battery pack installed in the WMX101 serves as backup in the event of a power failure, when it will keep the meter operating without interruption for the duration of the outage. When battery power is in use, the WMX101 display continues to read out the rate and total, but the “P” indicating external power is extinguished. When power resumes, the WMX101 will seamlessly return to normal power mode, and the “P” will again display.

When used for occasional emergency backup, battery life is approximately ten years.

**Pulse Output (WMX101).** The WMX101 cable also provides pulse output that can be used for remote reading, 4-20 mA signal conversion, datalogging, and telemetry applications. See page 7 for connection diagrams to Seametrics controls and displays.

Pulse rates are selected by the customer at time of order, factory-set, and can only be changed in the field by an authorized Seametrics dealer. Three pulse rates are possible: One pulse per ten gallons (or liters), one pulse per thousand gallons (or liters), or High Frequency (required for use with 4-20 mA converters; see below):

High Frequency Output/K-Factor		
Meter Size	Pulses per Gallon	Pulses per Liter
4"	16.362	4.323
6"	6.307	1.666
8"	3.344	0.883
10"	2.150	0.568

### WMX104

**Battery Power (WMX104).** The WMX104 is powered by a non-rechargeable battery pack with an average lifespan of one year under typical (full-time) use. Actual lifespan will vary from application to application, depending on the duty cycle.

“Low Batt” will display when there are approximately three days of use left in the batteries (see illustration). Replacement instructions come with the custom battery pack available from your dealer or Seametrics.

**Pulse Output (WMX104).** Pulse output capabilities are built in to the WMX104, but cannot be utilized without the addition of an optional output cable. A WMX104 can be retrofitted with this cable in the field. **IMPORTANT:** *When field installing the input/output cable, be sure to snugly tighten the cable strain relief to prevent water ingress.*

### OPERATION



**Caution:** There are no user-adjustable connections or settings inside the display housing. Use caution when opening the housing for a battery change, to avoid damage to internal components.

**Display Reading.** The WMX display has two lines, the bottom line for flow rate and the top line for accumulated total. Measurement units are pre-ordered and factory-set and can be changed in the field only by an authorized individual.

Refer to the diagrams below to read your display.

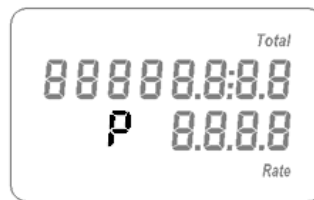

**External Power Indicator**  
(WMX101 Only)



**No Power**



**Battery Power**  
(WMX104 Standard Operation)  
(WMX101 Backup Operation)



**Empty Pipe**

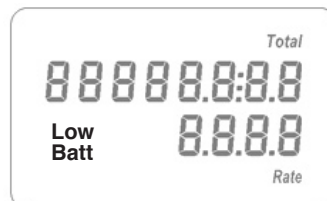

**Low Battery Indicator**  
(3 days remaining)

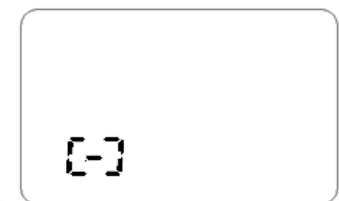

**Meter Installed Backwards**

## CONNECTIONS DIAGRAMS (WMX101)

The **WMX101** requires a power source of 7 to 26 Vdc at 30 mA max (see **WARNING**). The WMX101 power cable also serves as a pulse output if needed for remote reading, data logging, signal conversion, or telemetry.

### WMX101 Cable Color Codes

**Orange and Blue:** Serial Output (Do Not Use)

**Green (+) and White (-):** Pulse Output, 30 Vdc max, 10 mA max

**Red (+) and Black (-):** External Power, 7-26 Vdc at 30 mA max

**Drain:** Connect to earth ground (see **WARNING**)

### A055/WMX101

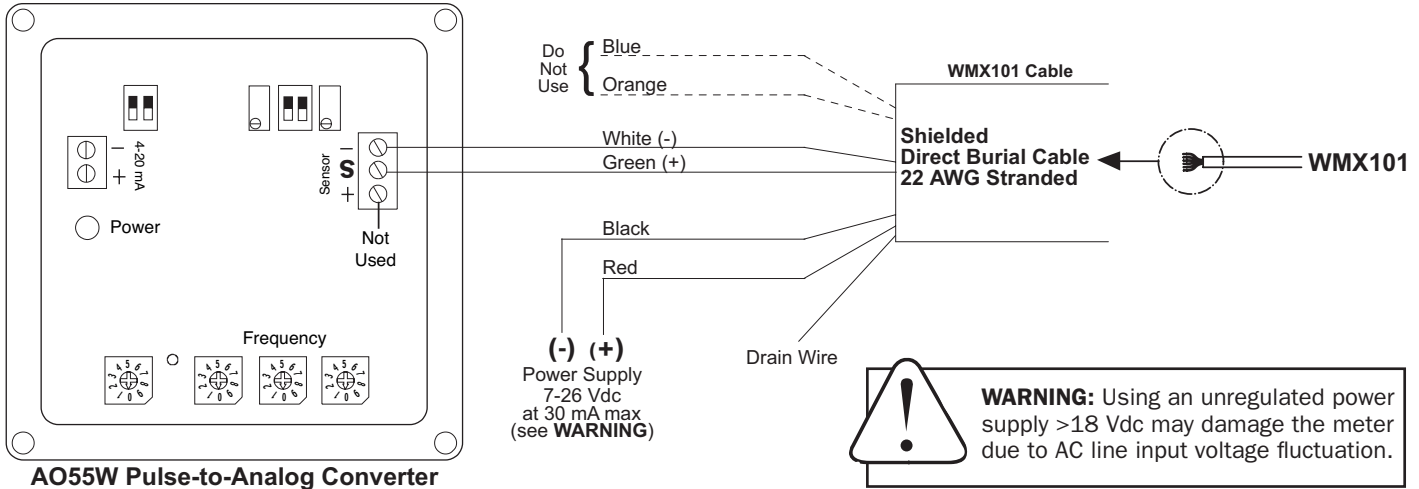

### FT420/WMX101

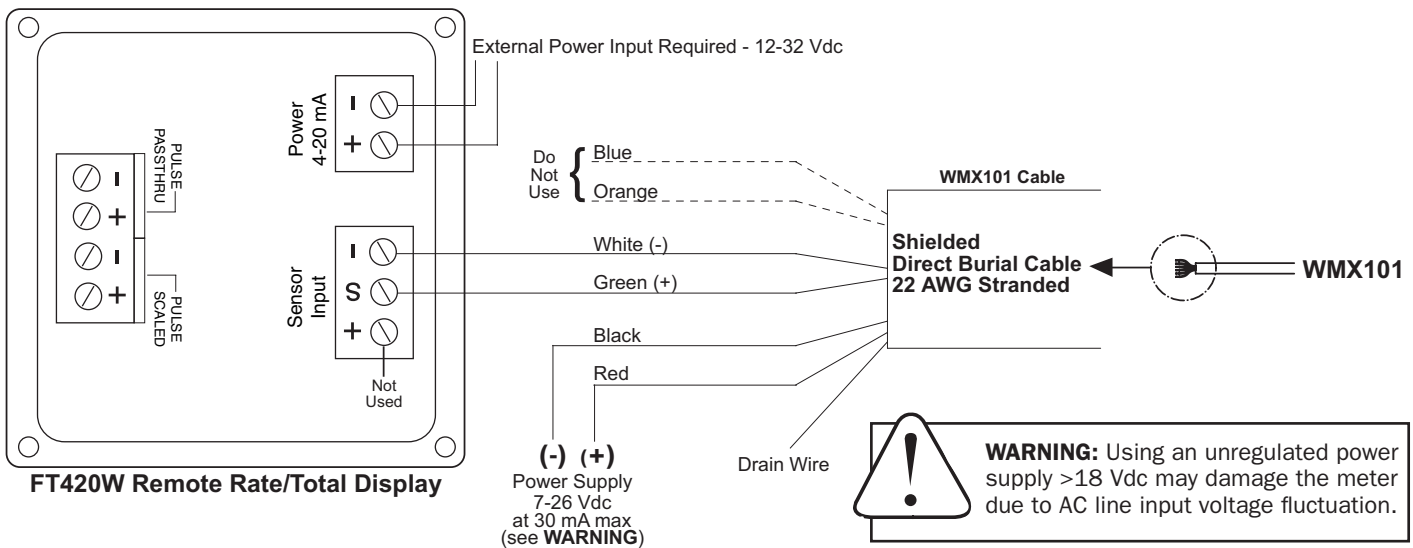

### DL75 or DL76/WMX101

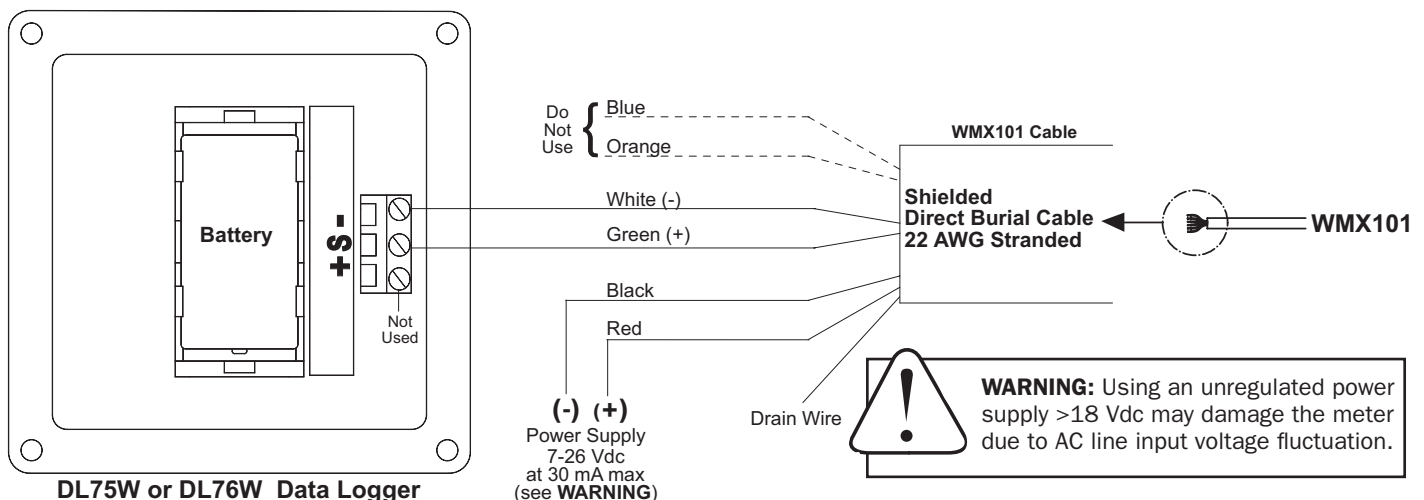

## TROUBLESHOOTING

Problem	Probable Cause	Try...
Blank Display	Dead battery (WMX104)	Replace battery pack
	No power plus dead battery (WMX101)	Replace battery pack, check power connections
Flow rate steadily reads zero when there is flow	Flow is below cutoff (very low)	Reading will resume when flow increases
	Pipe not full	Reposition meter for full pipe (see page 4)
	Meter is installed backwards (display reads [ - ] )	Note flow direction arrow, reverse meter
	Power connections reversed (WMX101)	Change power connections
	Fluid conductivity <20mSiemens/cm	Select another flow meter
Flow rate intermittently drops when there is flow	Pipe not full	Reposition meter for full pipe (see page 4)
Jumpy reading	Missing or incorrect ground wire	Check for proper ground
	Pulsing flow	Use external power source (allows more flow averaging)
	Rapidly changing conductivity (in chemical injection applications)	Install chemical injection line downstream of meter (or far enough upstream to allow complete mixing of fluids before meter)
Meter reads, but no pulse output (WMX101)	External device needs pull-up resistor	Add pull-up resistor
	Reversed leads (polarity sensitive)	Change output connections
Output pulses missing	Meter not reading	Check display



**Seametrics Incorporated • 19026 72nd Avenue South • Kent, Washington 98032 • USA  
(P) 253.872.0284 • (F) 253.872.0285 • 1.800.975.8153 • [www.seametrics.com](http://www.seametrics.com)**