

# EM100/102

## LOW FLOW MAGNETIC FLOWMETER INSTRUCTIONS



EM100/102 LOW FLOW MAGNETIC FLOWMETER INSTRUCTIONS

**ISO** 9001:2000  
CERTIFIED

**SeaMetrics**

The Leader in Flow Meter Value

## GENERAL INFORMATION

The EM100/102 are small electromagnetic low-flow flow-meters with chemically-resistant plastic wetted parts and a choice of Hastelloy or platinum electrodes suitable for use with a variety of chemicals. Capable of measuring pulsating flows from diaphragm-type metering pumps, they are designed primarily for electrically-conductive chemical injection applications. The 1/4", 3/8", and 1/2" sizes monitor maximum flows of 1, 3, and 8 gallons per minute (or 4, 11, and 30 L/min), respectively. Barb or NPT fittings are available.

The EM100 and EM102 are 12-24 Vdc powered. The EM100 comes with a standard pulse output, and the EM102 with standard pulse and analog outputs. All electronics are self-contained in a single compact chemically-resistant housing, well suited for OEM applications.

These meters are also appropriate for remote monitoring of chemical volume or rate using a computer or a PLC.

## FEATURES

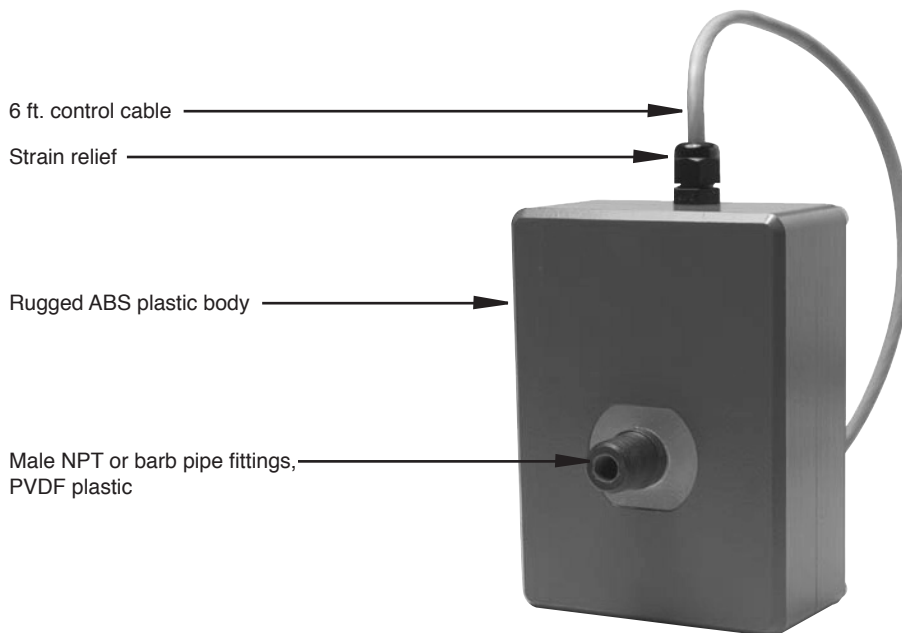

## SPECIFICATIONS

	EM100	EM102
<b>Materials Body</b>	ABS plastic	ABS plastic
<b>Electrodes</b>	Platinum or Hastelloy	Platinum or Hastelloy
<b>O-Ring</b>	Viton™ (EPDM optional)	Viton™ (EPDM optional)
<b>Fittings</b>	PVDF plastic	PVDF plastic
<b>Power</b>	12-24 Vdc, 180 mA	12-24 Vdc, 180 mA
<b>Accuracy</b>	+/-1% of reading, plus .005 gpm (0.02 lpm)	+/-1% of reading, plus .005 gpm (0.02 lpm)
<b>Max Fluid Temperature</b>	185° F (85° C)	185° F (85° C)
<b>Maximum Pressure</b>	150 psi (@ 75° F)	150 psi (@ 75° F)
<b>Minimum Conductivity</b>	20 microSiemens	20 microSiemens
<b>Outputs</b>	Frequency opto isolated 1000 pulse/liter (3785 p/g)	<ul style="list-style-type: none"> <li>• Frequency opto isolated 1000 pulse/liter (3785 p/g)</li> <li>• 4-20 mA opto isolated passive</li> </ul>

## FLOW RANGE

SIZE	LOW FLOW CUTOFF			MINIMUM FLOW for spec accuracy			MAXIMUM FLOW		
	L/MIN	GAL/MIN	GAL/HR	L/MIN	GAL/MIN	GAL/HR	L/MIN	GAL/MIN	GAL/HR
-025	.04	.01	.60	.26	.07	4.2	3.8	1	60
-038	.11	.03	1.80	.76	0.2	12	11	3	180
-050	.26	.07	4.20	1.9	0.5	30	30	8	480

# INSTALLATION, CONNECTIONS, and OPERATION

## INSTALLATION

**Mounting.** The EM100/102 can be supported by its piping connections if the piping is rigid and there is no vibration. Alternatively, the grounding studs can be used for mounting by inserting them through pre-drilled holes. Note the centerline distance in the dimensional drawing below.



**CAUTION:** Although this meter has an empty pipe detection function, under certain conditions of empty or partially-full pipe the meter may read a flow when there is none. If this is a hazardous condition, mount the meter in such a way as to ensure the meter will always be full of liquid.

**Piping.** Metallic pipe or tube, or plastic tubing, can be used with the meter. The meter has male NPT or barb pipe fittings. For plastic tubing, use female NPT tubing adaptors. In installations exposed to vibration, it is not recommended to use the piping as the sole support for the meter, particularly on the smaller sizes.

A minimum of 1" of straight pipe run is recommended on the inlet side of the meter. Straight run is not necessary on the outlet.

## CONNECTIONS

Power and signal connections are provided by the single 4- or 6-conductor color-coded cable. See the Connections chart, back page. In addition, it is necessary for proper operation to ground the unit to a good quality earth ground. Use the 12 ft. grounding wire supplied with the unit, or if necessary, a longer wire attached to one or both of the grounding studs. If metal piping is used, ground connections from the grounding studs on the bottom of the unit to both inlet and outlet pipes provide the best results in metering accuracy. See Grounding diagrams, back page.

## OPERATION

The newly-installed meter takes from a few seconds to a minute for the signal to stabilize at startup, especially if it has been dry. In normal operation, keep the meter filled with fluid to prevent this delay. An empty pipe detection feature will normally detect absence of liquid in the pipe and register zero flow when the meter is mounted properly.

The optional **4-20 mA signal** outputs 4 mA at zero flow and 20 mA at maximum rated flow. The **standard pulse signal** is a 50% duty cycle pulse set at 1000 pulses/liter (3785 pulses/gallon).

## DIMENSIONS

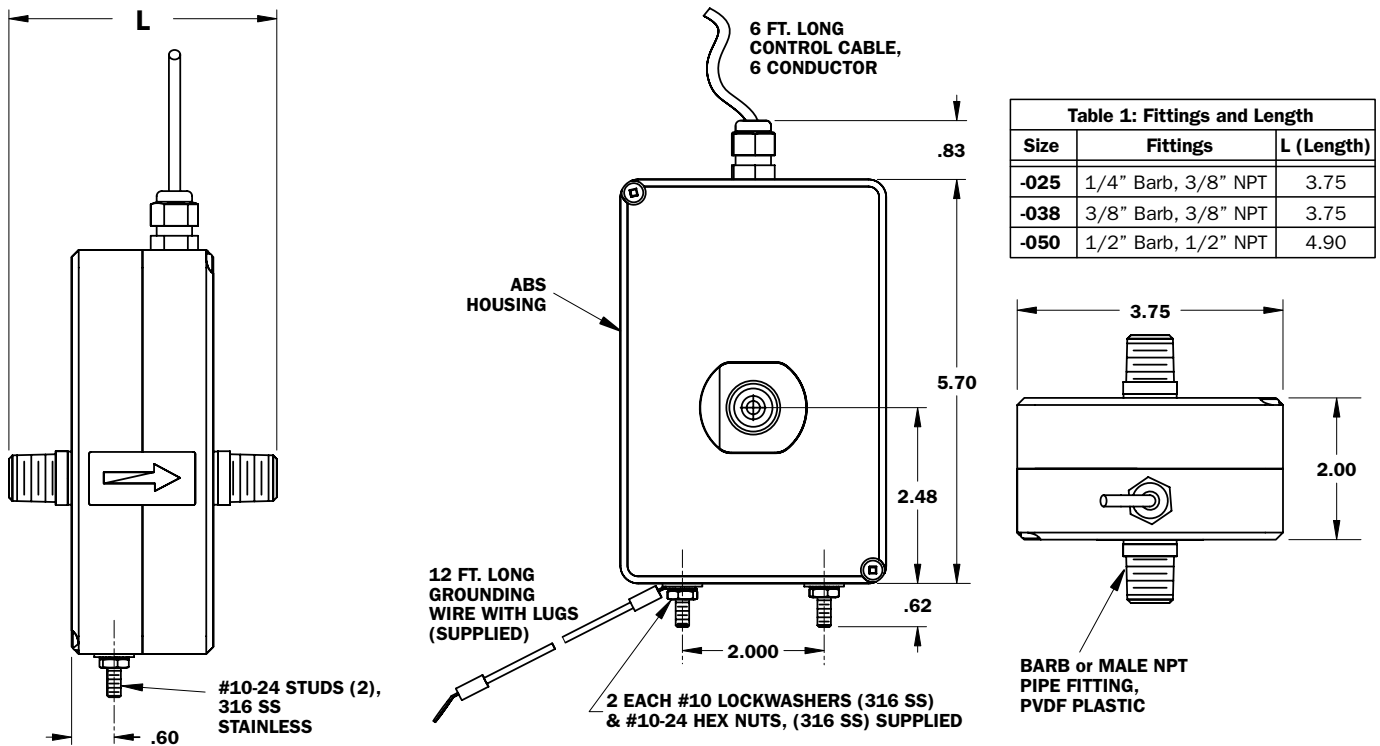

# GROUNDING and TROUBLESHOOTING

## IDEAL GROUNDING WITH METALLIC PIPING

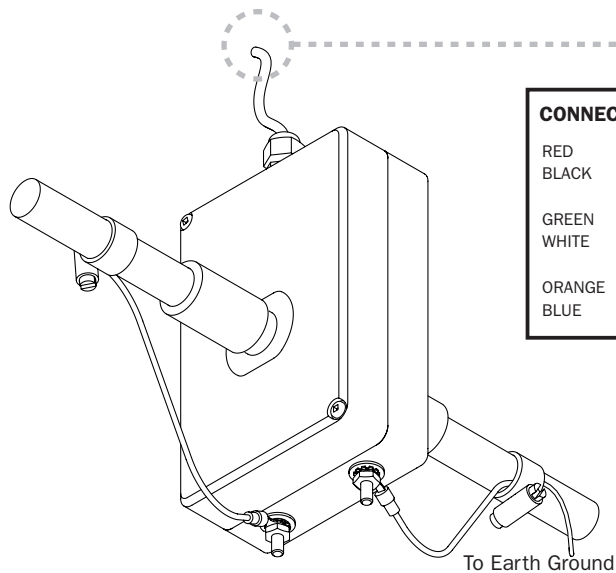

CONNECTIONS		
RED	+ 12 to 24 Vdc Power	
BLACK	- Power	
GREEN	+ Pulse Output Isolated	
WHITE	- Pulse Output Isolated	
ORANGE	+ 4-20 mA Isolated	} Optional
BLUE	- 4-20 mA Isolated	

## STANDARD GROUNDING

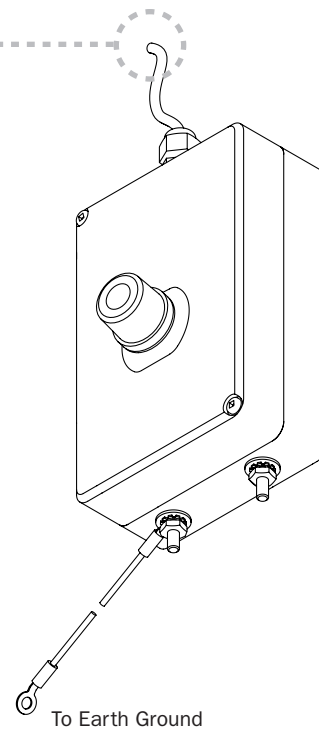

## TROUBLESHOOTING

Problem	Probable Causes	Try...
Analog output at 0 mA	No loop power	4-20 mA loop needs an external power supply - if missing, add it
Analog output is 4 mA with flow	Unit not grounded Flow reversed	Connect to earth ground Note flow direction arrow, reverse direction to match
No pulse output	Reversed output connections Not grounded Reversed flow	Change output connection Connect to earth ground Change flow direction
Flow rate incorrect	Missing or incorrect ground wire Fluid conductivity <20 microSiemens/cm Empty pipe	Check for proper grounding Select another flow meter Install meter in vertical position

