

IP100/200-SERIES

Seametrics

ADJUSTABLE DEPTH INSERTION PADDLEWHEEL INSTRUCTIONS

IP100/200-SERIES INSERTION PADDLEWHEEL INSTRUCTIONS

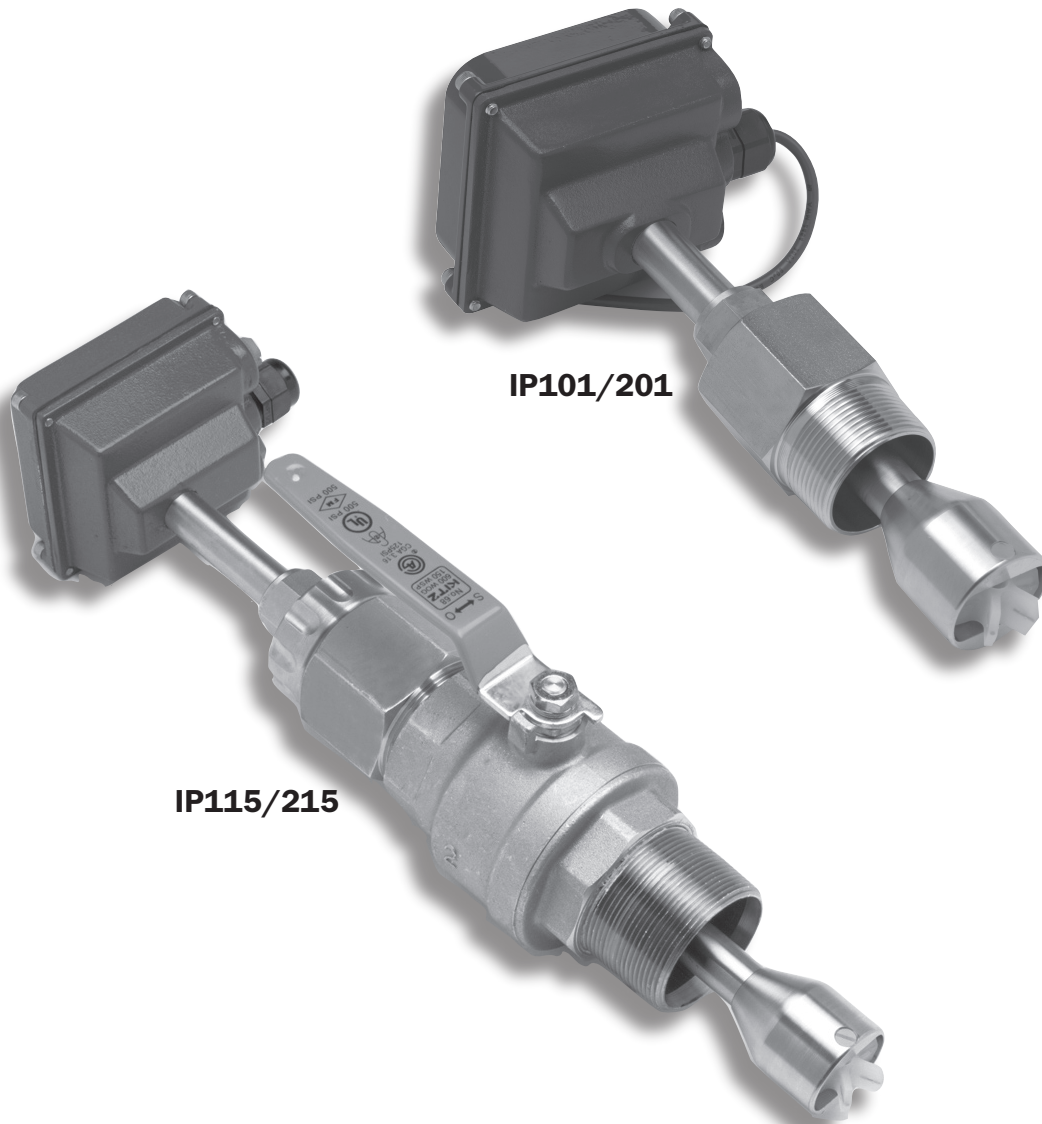

IP101/201

IP115/215

TABLE OF CONTENTS

General Information

General Information, Features, Specifications..... Page 1

Installation

Piping, Positioning the Meter, Immersion, Depth Setting..... Page 2

IP101/201 Installation, IP115/215 Installation Page 3

Dimension C, Pipe Wall Thickness Page 4

Flow Rate, K-Factors Page 5

Straight Pipe Recommendations..... Page 6

Full Pipe Recommendations Page 7

Connection, Operation & Repair

Calibration, Theory of Operation, Flow Range, Rotor Replacement..... Page 8

Repair & Parts

Signal, Parts Explosion, Parts List..... Page 9

Troubleshooting

Problem, Probable Cause, To Try Back

TABLES AND DIAGRAMS

Features..... Page 1

Specifications Table..... Page 1

Piping..... Page 2

Positioning the Meter Page 2

Depth Setting..... Page 2

Meter Installation Page 3

Table 1 (Dimension C), Table 2 (Pipe Wall Thickness)..... Page 4

Table 3 (Flow Chart), Table 4 (IP100/200 K-Factors)..... Page 5

Straight Pipe Recommendations..... Page 6

Full Pipe Recommendations Page 7

Connection Diagram Page 8

Rotor Replacement..... Page 8

Parts Explosion..... Page 9

Parts List Page 9

Troubleshooting: Problem, Probable Cause, To Try Back

GENERAL INFORMATION

GENERAL INFORMATION

The IP100/200-Series are adjustable depth insertion paddlewheels that come in brass or 316 stainless models to fit 3" to 48" pipe. Installation fittings are standard 1-1/2" or 2" NPT. Fittings such as saddles and weldolets may be purchased either locally or from Seametrics.

Ruby bearings and a non-drag Hall-effect sensor give these meters the widest flow range of any of the paddlewheel types. A sensor detects the passage of miniature magnets in the six rotor blades. The resulting square-wave signal can be sent for hundreds of feet over unshielded cable without a transmitter and connected directly to many PLC's and other controls without any additional electronics.

FEATURES

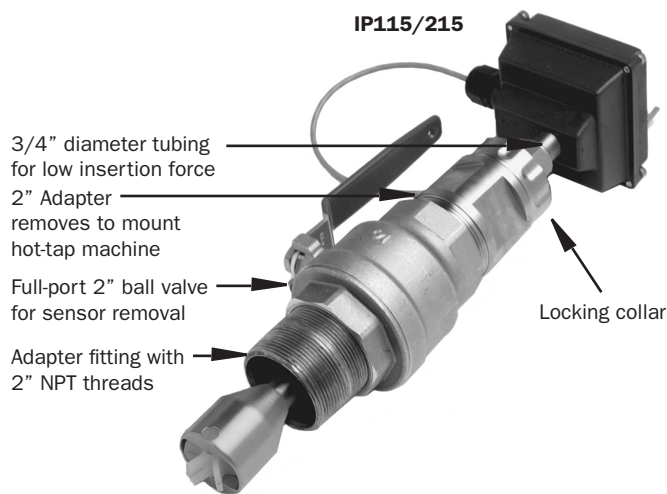

If desired, a modular system of electronics can be installed directly on the flow sensor or mounted remotely. The FT415 (battery powered) and FT420 (externally powered in a splash-proof cst housing) provide digital rate and total display, as well as programmable pulse output; the FT420 also provides a 4-20 mA analog output. The AO55 is a blind analog transmitter. Programmable pulse for pump pacing is available with the PD10.

The "hot-tap" models (IP115/215) can be installed or serviced without shutting down the line by means of a 2" full-port isolation valve that comes with a nipple for installation on the pipe fitting. In most circumstances, no special tool is required.

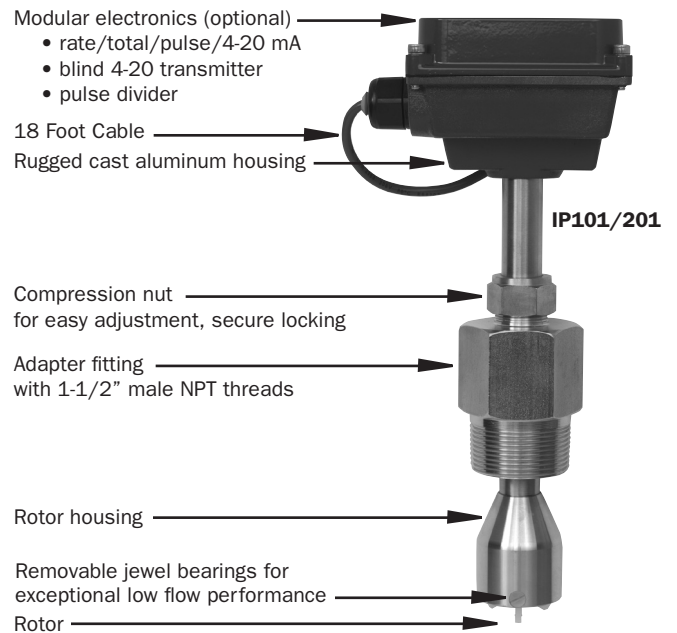

SPECIFICATIONS*

Pipe Size	IP101/115	IP201/215
	3" to 10" (50 - 250mm)	10" to 48" (250 - 1200mm)
Sensor	Hall Effect sensor, 12 Vdc current sinking pulse	
Materials	Housing Cast aluminum	
	Sensor Body Brass or 316 SS	
	Rotor PVDF (Kynar)	
	Shaft Nickel-bound tungsten carbide (zirconia ceramic optional)	
	Bearings Ruby jewel	
	IP101/201	IP115/215
Isolation Valve	None	Bronze (316SS optional)
Fitting Size	1.5" NPT	2" NPT
Flow Range	0.3 - 30 feet/sec (0.1 - 9 meter/sec)	
Accuracy	+/- 1.5% of full scale	
Maximum Temperature	200° F (93° C)	
Maximum Pressure	200 psi (14 bar)	
Insertion Force	0.44 x pressure in pipe	
Power	5-24 Vdc, 1.5 mA	
Cable	#22 AWG 3-con, 18' (6m); 2,000' (650m) maximum cable run	
Regulatory	CE Mark (Standard Power Only)	

*Specifications subject to change. Please consult our website for the most current data (www.seametrics.com).

INSTALLATION



These flow sensors are not recommended for installation downstream of the boiler feedwater pump where installation fault may expose the meter to boiler pressure and temperature. Maximum recommended temperature is 200° F.

Piping. For best results, the IP sensor should be installed with at least ten diameters of straight pipe upstream and five downstream. Certain extreme situations such as partially-opened valves are particularly difficult and may require fifteen diameters upstream. (See Straight Pipe Recommendations.)

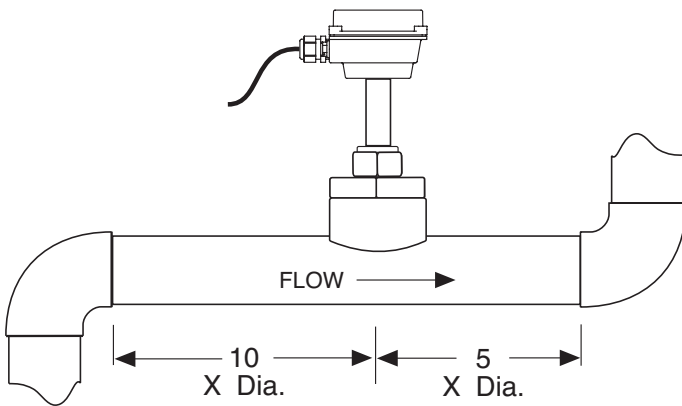

Horizontal is the preferred installation orientation, since it improves low-flow performance slightly and avoids problems with trapped air. Bottom, top, and vertical pipe installations are all acceptable if required by the piping layout. (See Full Pipe Recommendations.)

POSITIONING THE METER

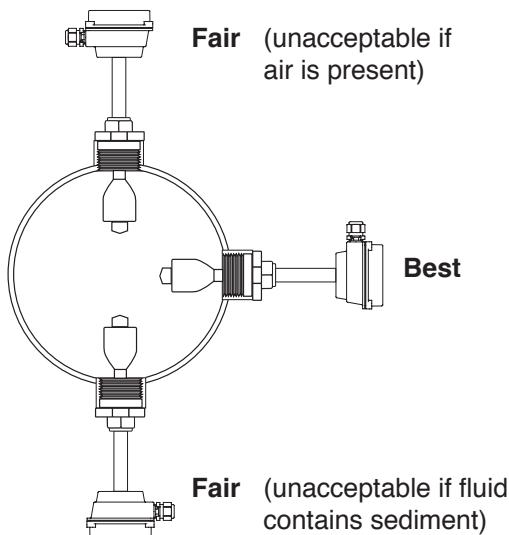

Immersion. The IP100/200 Series standard sensors are not designed for continuous underwater operation. If this is a possibility, as in a flooded vault, a unit modified for immersion should be specified (Option -40).

Depth Setting. It is important for accuracy that the sensor be inserted to the correct depth into the pipe.

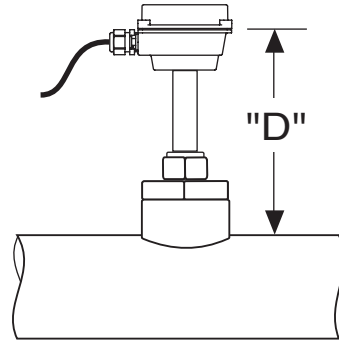

1. In Table 1 (page 4), find Dimension C for your sensor model and pipe size.
2. Subtract wall thickness of your pipe (Table 2) to find Dimension D.
3. Measuring from the outside of the pipe to the joint in the housing, as shown in the diagram above, adjust the sensor to Dimension D and hand-tighten compression nut.
4. Align the conduit housing with the centerline of the pipe, as shown. Be sure the arrow on the housing points in the direction of flow.

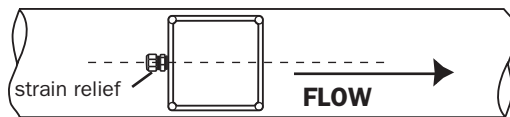

5. Check Dimension D one more time.
6. Tighten the compression nut fully.

RECORD YOUR SETTINGS

Once you have the meter set up and operational, it is important to record your meter settings and save them for future reference.

K-Factor _____
 Insertion Depth (Dim. D) _____

INSTALLATION

IP101/201 INSTALLATION

Fitting Installation. IP101/201 sensors come with a 1-1/2" male NPT pipe thread adapter fitting. Any fitting that provides the matching NPT female thread may be used. Installation procedure compensates for fitting height differences. Cut a minimum 1-3/4" hole in the pipe. If possible, measure the wall thickness and write it down for use in depth setting. Then install the threaded fitting (saddle, weldolet, etc.) on the pipe.

Meter Installation. Loosen the compression nut so that the adapter slides freely. Pull the meter fully upward and finger-tighten the compression nut. Using a thread sealant, install the adapter in the pipe fitting. Do not overtighten. Now loosen the compression nut, lower the meter to the appropriate depth setting (see diagram and instructions, preceding page). Be sure flow is in the direction of the arrow on the housing. Tighten compression nut fully.

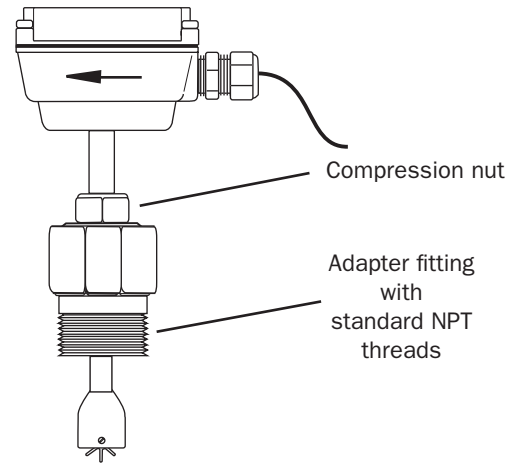

IP115/215 INSTALLATION

'Hot tap' IP meters are designed to be installed and serviced without depressurizing the pipe.

Fitting Installation. The IP115 and 215 sensors have a 2" NPT thread for compatibility with the 2" isolation valve. Any fitting that provides matching NPT female thread may be used. The installation procedure compensates for differences in fitting height.

If initial installation is performed on an unpressurized pipe, cut a minimum 1-3/4" hole in the pipe. If possible, measure the wall thickness and write it down for use in depth setting. Then install the threaded fitting (saddle, weldolet, etc.) on the pipe.

If it is necessary to do the initial installation under pressure, any standard hot tap drilling machine with 2" NPT adapter, such as a Transmate or a Mueller, can be used. Ordinarily, it is not necessary to use an installation tool, since the small-diameter tube can be controlled by hand at all but the highest pressures.

Meter Installation. Remove the sensor unit from the valve assembly. Using a thread sealant, install the valve assembly on the pipe fitting. If the initial installation is a pressure ("hot") tap, remove the 1-1/2" x 2" adapter bushing at the back of the valve. Thread the tapping machine on, open the valve, and tap using a minimum of 1-3/4" or maximum 1-7/8" cutter. After retracting the machine and closing the valve, reinstall the flow sensor. When the sensor is secure, open the valve and adjust depth setting (see diagram and instructions, preceding page). Be sure flow is in the direction of the arrow on the housing. Tighten locking collar and compression nut fully.

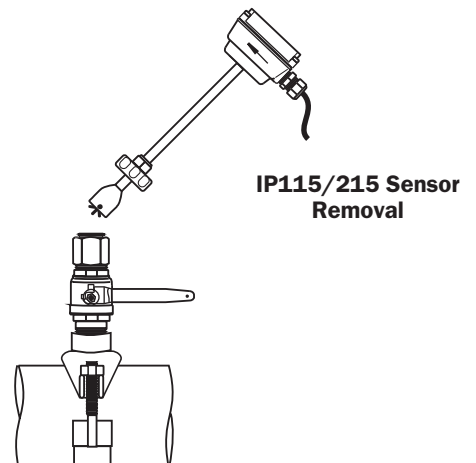
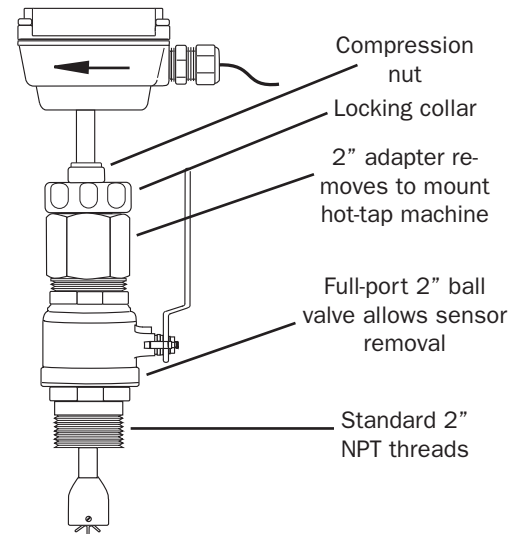

INSTALLATION

Table 1: Dimension "C" (inches)		Nominal Pipe Size												
	3"	4"	5"	6"	8"	10"	12"	14"	16"	18"	20"	24"	30"	36"
IP101	9.20	9.03	8.86	8.69	8.35	8.01	7.67	7.33	6.99	-	-	-	-	-
IP201	14.20	14.03	13.86	13.69	13.35	13.01	12.67	12.33	11.99	11.65	11.31	10.63	9.61	9.59
IP115	16.21	16.01	15.91	15.71	15.31	15.01	14.71	14.36	14.01	-	-	-	-	-
IP215	-	20.06	19.86	19.66	19.36	19.06	18.66	18.31	17.96	17.61	17.26	16.66	15.66	14.56

Table 2: Pipe Wall Thickness (inches)		Nominal Pipe Size												
	3"	4"	5"	6"	8"	10"	12"	14"	16"	18"	20"	24"	30"	36"
IPS/Steel Sch. 40	0.216	0.237	0.258	0.280	0.322	0.365	0.406	0.438	0.500	0.562	0.593	0.687	-	0.750
IPS/Steel Sch. 80	0.300	0.337	0.375	0.432	0.500	0.593	0.687	0.750	0.843	0.937	1.031	1.218	-	-
Stainless Steel (10S)	0.120	0.120	0.134	0.134	0.148	0.165	0.180	0.188	0.188	0.188	0.218	0.250	0.312	0.312
Stainless Steel (40S)	0.216	0.237	0.258	0.280	0.322	0.365	0.375	0.375	0.375	0.375	0.375	0.375	0.375	0.375
Copper Tubing (Type L)	0.090	0.100	0.125	0.140	0.200	0.250	0.280	-	-	-	-	-	-	-
Copper Tubing (Type K)	0.109	0.134	0.160	0.192	0.271	0.338	0.405	-	-	-	-	-	-	-
Brass Pipe	0.219	0.250	0.250	0.250	0.313	0.365	0.375	-	-	-	-	-	-	-
Duct. Iron (Class 52)	0.280	0.290	-	0.310	0.330	0.350	0.370	0.390	0.400	0.410	0.420	0.440	0.470	0.530

INSTALLATION

Table 3: Flow Rate in Sched. 40 pipe (in GPM)		Nominal pipe size										
Velocity (ft / sec)	3"	4"	5"	6"	8"	10"	12"	16"	24"	36"	38"	48"
0.3	6.9	11.9	18.7	27	46.8	73.7	105	165	376	874	1060	1690
0.5	11.5	19.8	31.2	45	78	123	174	275	627	1460	1770	2820
1.0	23	39.7	62.4	90	156	246	349	551	1250	2910	3530	5640
2.0	46.1	79.4	125	180	312	492	698	1100	2510	5830	7070	11280
5.0	115	198	312	450	780	1230	1740	2750	6270	14570	17670	28200
10.0	230	397	624	900	1560	2460	3490	5510	12530	29140	35350	56400
20.0	461	794	1250	1800	3120	4920	6980	11020	25060	58270	70700	112800
30.0	691	1190	1870	2700	4680	7370	10470	16520	37600	87410	106050	170000

Table 4: IP100/200 K-factors (pulses per gallon)		Nominal pipe size											
	3"	4"	5"	6"	8"	10"	12"	16"	24"	30"	36"	38"	42"
PVC/Steel Sch. 40	28.92	16.79	10.69	7.40	4.27	2.14	1.51	0.960	0.420	0.250	0.180	0.160	0.135
PVC/Steel Sch. 80	32.37	18.59	11.75	8.20	4.68	2.35	1.66	1.050	—	—	—	—	—
Stainless Steel (10S)	25.61	15.00	9.71	6.74	3.92	1.98	1.40	—	—	—	—	—	—
Stainless Steel (40S)	28.92	16.79	10.51	7.40	4.27	2.14	1.49	—	—	—	—	—	—
Stainless Steel (80S)	32.37	18.59	11.75	8.20	4.68	2.26	—	—	—	—	—	—	—
Copper Tubing (Type K)	32.21	18.12	11.79	8.26	4.73	—	—	—	—	—	—	—	—
Copper Tubing (Type L)	31.39	17.85	11.46	7.97	—	—	—	—	—	—	—	—	—
Brass Pipe	29.03	17.01	10.62	7.26	4.25	—	—	—	—	—	—	—	—
Duct. Iron (Class 52)	25.93	15.28	—	6.90	3.86	1.99	1.39	0.780	—	—	—	—	—

INSTALLATION

STRAIGHT PIPE RECOMMENDATIONS

(X = diameter)

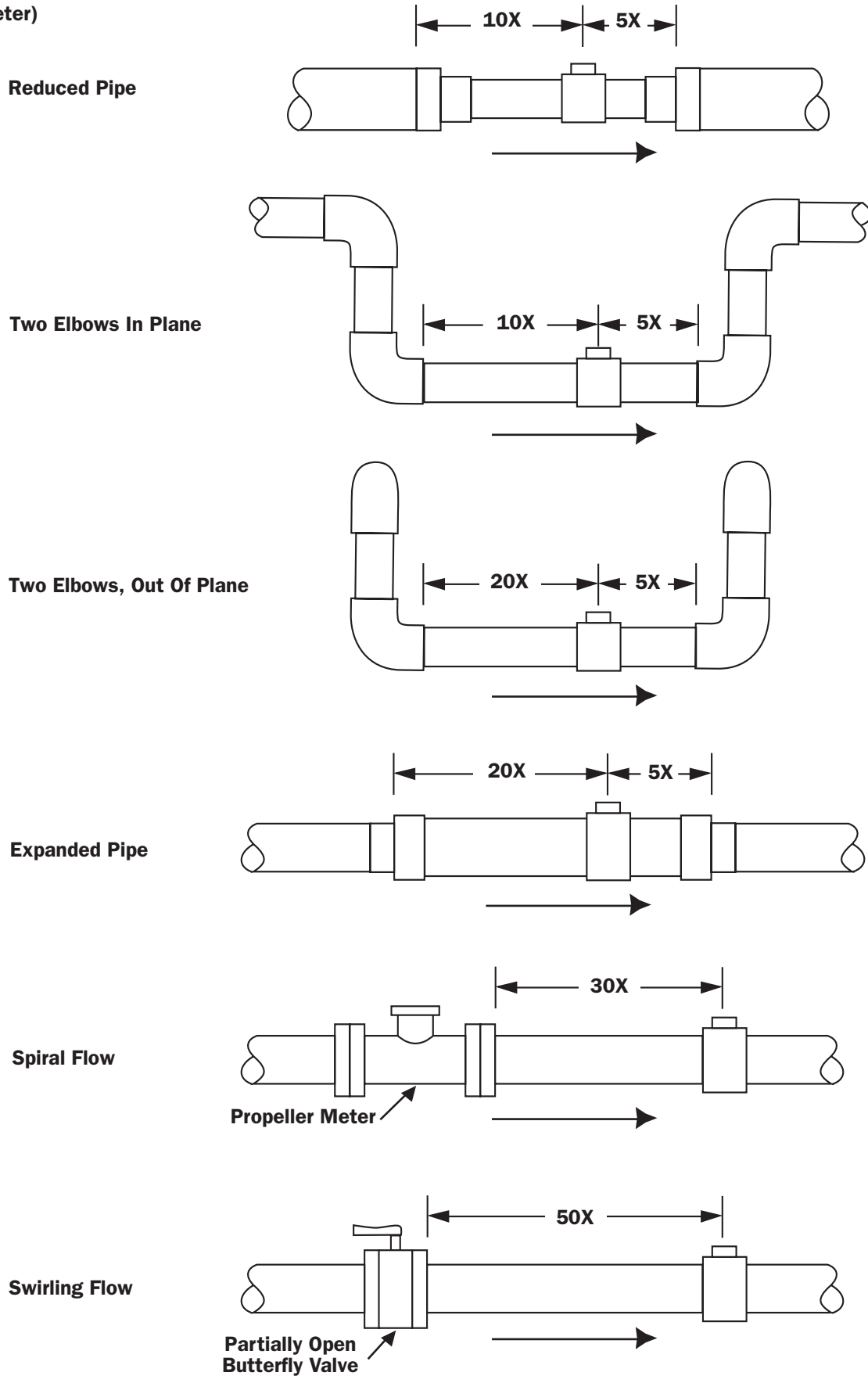

INSTALLATION

FULL PIPE RECOMMENDATIONS

NOT RECOMMENDED

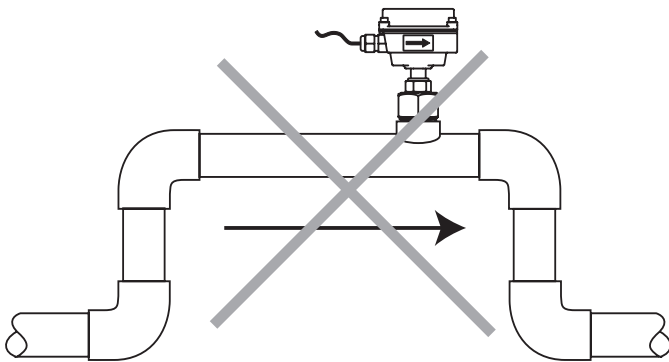

Allows air pockets to form at sensor

RECOMMENDED

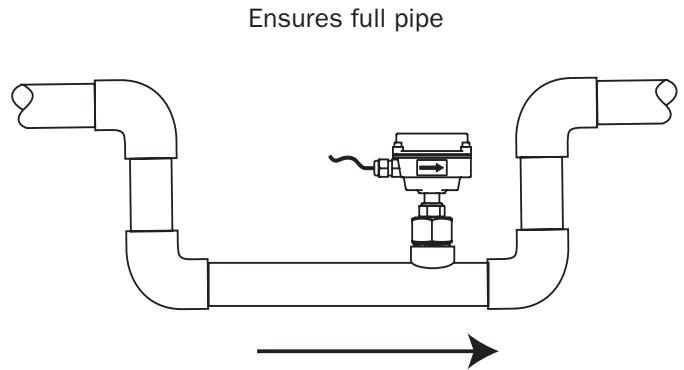

NOT RECOMMENDED

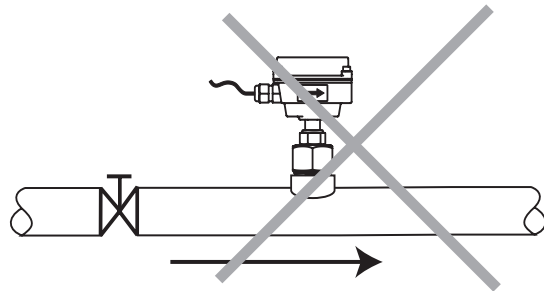

Post-valve cavitation can create air pocket

RECOMMENDED

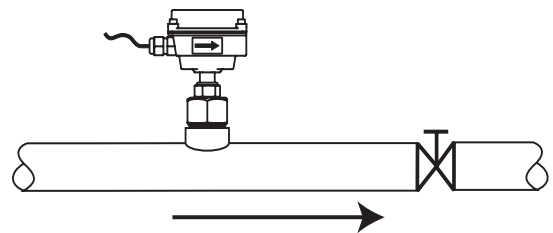

Keeps pipe full at sensor

NOT RECOMMENDED

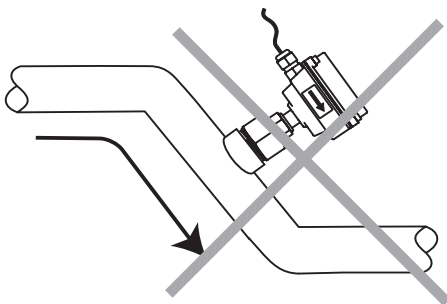

Air can be trapped

RECOMMENDED

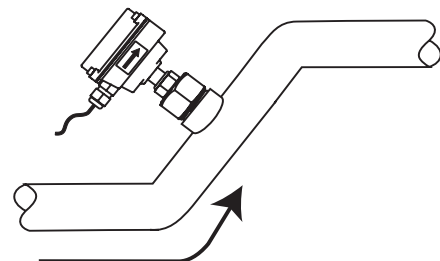

Allows air to bleed off



Caution: These flow sensors are not recommended for installation downstream of the boiler feedwater pump where installation fault may expose the flow sensor to boiler pressure and temperature. Maximum recommended temperature is 200°F.

CONNECTION

Sensors are supplied with 18 ft. of cable. For sensors with no additional electronics, see diagram for color coding of connections. For sensors with on-board electronics, see the manual accompanying the electronic module.

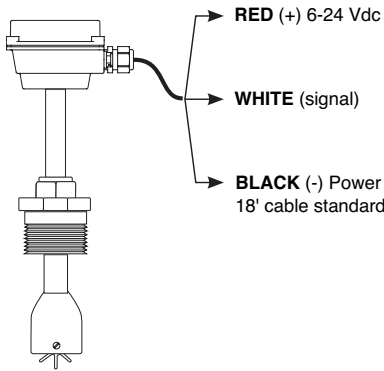

Calibration (“K-Factor”). In order to properly process pulses from the flow sensor, a number must be entered into the control to which the sensor is connected. This number, called the K-factor, is the number of pulses the sensor puts out per unit of fluid passing through the pipe. It is normally provided for Seametrics sensors in pulses per gallon, and is given on the chart “K-factors for Various Pipe Sizes.” These numbers are based on extensive testing, which has shown close agreement between different IP sensors in the same installation. Typically, most K-factor error can be attributed to installation variables, such as depth setting and fitting configuration.

It is occasionally possible to field calibrate a sensor by catching the fluid in a measured container and comparing with the number of pulses recorded. (To record individual pulses, set the K-factor on the control to 1.00.) This is especially desirable if the installation has less than the recommended length of straight pipe upstream of the sensor.

OPERATION

Theory. In principle, an insertion flow sensor measures the velocity of flow at one point in the pipe, and flow rate and total can be inferred from this one point. Accuracy is decreased by any factor which makes the flow at the measured point unrepresentative of the entire flow stream. This includes distorted flow patterns caused by upstream fittings too close to the sensor. The worst offenders are fittings that increase the flow on one side of the pipe, such as partially-opened gate or butterfly valves. Fluid moving in a pipe does not all flow at the same velocity. Toward the center of the pipe, fluid moves faster than at the wall, and the relationship between the two changes as overall flow rate increases. This change in the “velocity profile” can result in non-linearity, which means that the K-factor that is correct for one flow rate may be incorrect for another. The recommended depth settings have been carefully chosen to minimize this source of error, and should be followed carefully, especially in the smaller pipe sizes.

Flow Range. These sensors are designed to operate at flow velocities of 0.3 to 30 feet per second. (See chart for conversion to gallons per minute.) If erratic readings are encountered at low flows, check the chart to see if flow is below minimum for the pipe size. The standard shaft and bearings should have a long life at continuous high flow.

REPAIR



Caution! Never attempt to remove a flow sensor when there is pressure in the pipe unless it is specifically designed for hot tap installation and removal. Loosen the compression nut slowly to release any trapped pressure. If fluid sprays out when removing the sensor, stop turning and depressurize the pipe. Failure to do so could result in the sensor being thrown from the pipe, resulting in damage or serious injury.

Rotor Replacement. Rotors are easily field-replaced. Shaft and rotor are a single unit, and are not replaced separately. If replacement is due only to normal shaft wear, bearing replacement is probably not necessary. If the rotor has been damaged by impact, the bearings should also be replaced. Rotor and bearings can be ordered as a kit, Part No. 25902. Follow these steps:

1. Unscrew the threaded bearing housings to expose the shaft ends. If bearings are being replaced, back them completely out.
2. Remove the rotor. Put the new rotor in its place.
3. Thread in one bearing housing part way, then the other. Take care to start the end of the shaft into the bearing hole before tightening further.
4. Screw in bearing housings until they bottom.
Note: Do not use excessive force.
5. Check for free spin. Blowing lightly on the rotor should result in it spinning rapidly and coasting to a smooth stop.

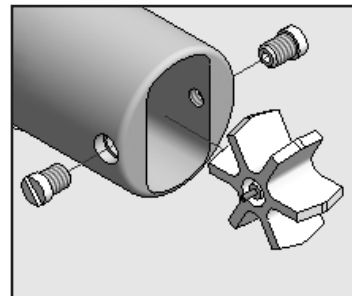

REPAIR & PARTS

All Seametrics flow sensors are repairable, and can be returned to the factory or distributor for repair after a Return Material Authorization (RMA) number has been issued.

Signal

The flow sensor has only one moving part, the rotor. If this is turning properly and there is no signal, the Hall-effect sensor is not operating properly. To check the signal, apply 12 Vdc regulated* power to the red (+) and black (-) leads. Set a multimeter to voltage reading. Put the positive multimeter lead on the red wire and the negative lead on the white wire. Slowly turn the rotor. Voltage reading should swing between +12 Volts and 0 Volts as the rotor turns. If it does not, the Hall effect sensor is not working properly. Checking for continuity is not a useful test of these sensors.

***NOTE:** An unregulated power supply can exceed max voltage of micro powered sensor (gray cable) and damage sensor.

Parts Explosion

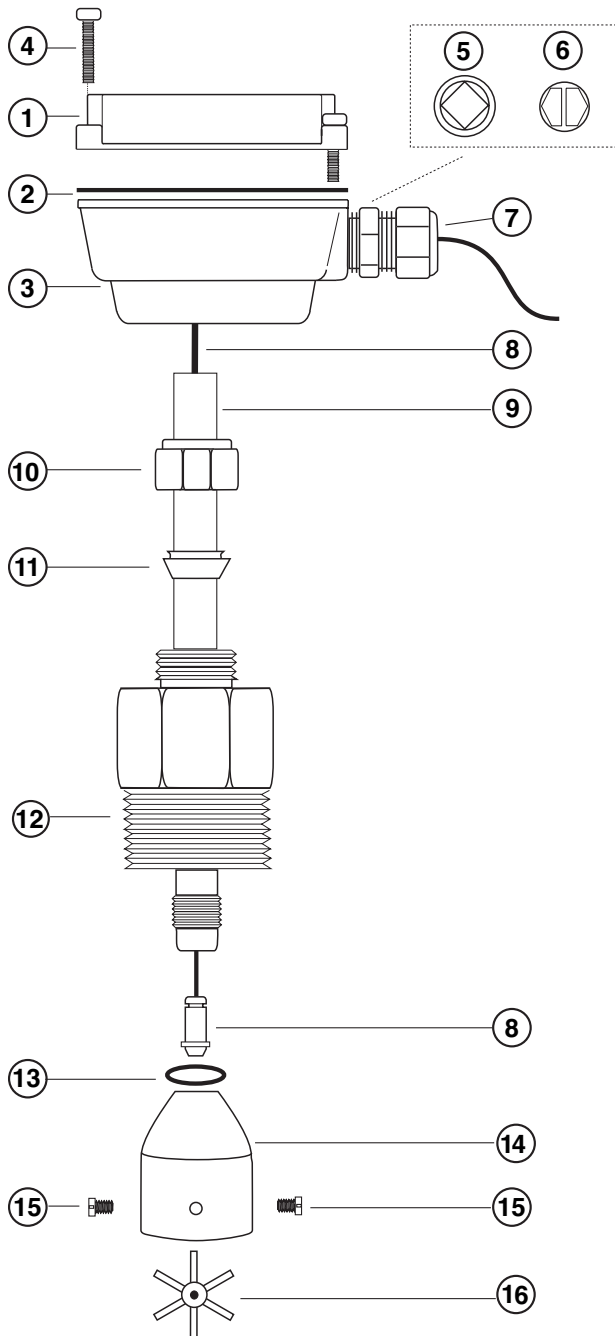

IP101/201 Parts

IP101/201 Parts		
1	Upper housing assembly	30475
2	Gasket	26211
3	Lower housing	Not Field Replaceable
4	Housing screw (4 req'd)	26229
5	Plug, steel	26073
6	Plug, plastic	26079
7	Strain relief	07655
8	Pickup, Micropower (for FT415)	29953
	Pickup, Standard (for FT420)	26310
9	Tube	Not Field Replaceable
10	Compression nut	14199 (Brass) 15064 (S/S)
11	Compression ferrule	26065
12	Adapter fitting	30998 (Brass) 30999 (S/S)
13	Rotor housing O-ring (EPDM)	16454
14	Rotor housing	14220 (Brass) 15220 (S/S)
15	Jewel bearings (2 req)	25901
16	Rotor with shaft	11130 (Kynar/Tungsten Carbide) 11132 (Kynar/Ceramic)
17	Rotor repair kit (includes of #15 & #16)	25902 (Kynar/Tungsten Carbide) 12131 (Kynar/Ceramic)

HOT TAP: IP115/215 Parts (not shown)

HOT TAP: IP115/215 Parts (not shown)		
Adapter fitting	14180 (Brass) 15060 (S/S)	
Ball valve assembly	14225 (Brass) 15225 (S/S)	
Collar, locking	14190 (Brass) 15070 (S/S)	
Hex nipple, 2"	14210 (Brass) 15100 (S/S)	

TROUBLESHOOTING

Problem	Probable Cause	Try...
No pulse output	Below minimum flow cutoff Empty pipe No power	Check Table for velocity vs. pipe size Check plumbing Check connections
Output pulses incorrect	Incorrect depth setting Pipe not full Not enough straight pipe	Check depth setting from Dimension "C" table Refer to Installation/diagrams Refer to Installation/diagrams
Jumpy reading	Fluctuating flow rate Fluctuating around low flow cutoff Not enough straight pipe	Refer to installation diagrams Check Table for velocity vs. pipe size Refer to Installation/diagrams

