



Figure 1. 6600 Series Magnetic Flowmeter

The Magmeter 6600 is an in-line electromagnetic flowmeter recommended for applications involving conductive liquids or slurries.

Principle of Operation (See Figure 2)

The Magmeter 6600 operates on the principle of electromagnetic induction, applying a controlled electromagnetic field (2) in the metering tube by way of coils (1). Conductive fluid flowing through the electromagnetic field generates a voltage proportional to its velocity. Sensing electrodes (4) on the inner surface of the metering tube detect the induced voltage, which the unit further converts into a volumetric flow rate. The Magmeter 6600 features a noise reduction function, in which a grounding electrode (6) detects ambient noise.

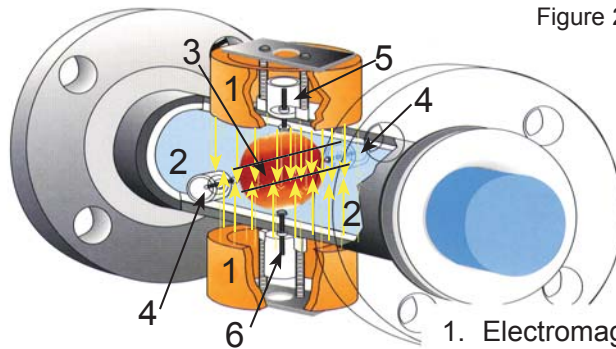

Figure 2

1. Electromagnetic coil
2. Magnetic field
3. Electrostatic field
4. Sensing electrodes
5. Empty Pipe electrode
6. Grounding electrodes

Basic Magmeter Equation

$$E = \text{Constant} \times B \times L \times V$$

where,

- E = induced voltage
- B = magnetic field density
- L = distance between the sensing electrodes

Recommended Applications

Chemicals	Acids, bases, corrosives, slurries, suspensions
Water & Waste Treatment	Waste water, sludges, potable water
Food & Beverage	Raw Materials & waste products
Pulp & Paper	Pulps, liquor, chemicals

Features of the Magmeter 6600 Series

Ease of Installation & Maintenance	Grounding rings not required; No moving parts
Accuracy	High accuracy, +/- 0.5% of flow rate; Independent of fluid viscosity, density, temperature, or solids content.
Does not affect Process Conditions	Negligible pressure drop across flowmeter



6600 Series Magmeter

Functional Specifications

Fluid Types	Conductive Liquids > 5µS/cm
Fluid Pressure	150 PSI, Consult factory for higher ratings
Fluid Temperature	PTFE (Teflon): -4 to 176 F Integral PTFE (Teflon): -4 to 248 F Remote Hard Rubber (Ebonite): 32 to 158 F
Vacuum Limits	Consult Factory
Low Flow Cut-Off	Set at 0.164 ft/sec (typical)
Magnetic System	Pulsed DC
Voltage	90VAC to 265VAC, 50/60 Hz
Outputs	<ol style="list-style-type: none"> Current - 4-20mA DC; 800 ohms max Pulse - Open collector 24 VDC; 200 ohms min load, programmable "on" time from 1 to 99msec. 1 Pulse = The least significant digit on the totalizer Frequency = 0-1000Hz 1000Hz = programmed full scale flow rate Relays - Two SPDT 2A @ 230VAC, #1 - for high flow or bi-directional #2 - for low flow or empty pipe <p>Empty Pipe Detection also indicated as "EPD" on display</p> <p>Bi-directional Flow also indicated as "BDF" on display; forward (+) & reverse (-) indication with separate totalizers</p>

Performance Specifications

Accuracy	+/- 0.5% of rate over 10:1 turndown ½" to 12" +/- 1.0% of rate over 10:1 turndown 14" to 24"
Repeatability	+/- 0.1% of full scale
Full Scale Flow	1.6 to 32 ft/sec
Response Time	2 sec
Velocity Range	0.16 to 32 ft/sec
Agency Approvals	FM3810 (General Purpose) for ½" to 24" FM3611 (Class 1 Div II, Group C&D) for ½" to 6"
Protection	IP 67 (1 meter immersion in water for 30 minutes)

Physical Specifications

Materials of Construction	
Liner	PTFE (Teflon): ½" to 12" Hard Rubber (Ebonite): 3" to 24"
Electrodes	Hastelloy C (standard) SS316L, Titanium, Platinum-Rh, and Monel (optional); Consult factory for more materials
Metering Tube	Not wetted - 304 SS
Coil Housing	Not wetted - Carbon Steel, Polyurethane painted
Flanges	Not wetted - Carbon Steel, Polyurethane Painted; SS304 (optional)
Electronics Housing	Not wetted - Cast Aluminum, Polyurethane painted
Connections and Mountings	
Mounting	Vertical, horizontal, or angle. Pipe must be full. Grounding rings not required.
Pipe Requirements	Upstream: 5 X ID (See IOM Manual M600) Downstream: 3 X ID
Process Connections	ANSI Class 150 RF (standard) ANSI Class 300 RF (optional)

Electronics Specifications

Temperature	-4 to 140 F
Connections	½"NPT

Flow Ranges/Dimensions/Weights

Flow ranges based on line size and ANSI Class 150

Line Size	minimum measurable flow (GPM)	minimum 20 mA setting (GPM)	maximum 20mA setting (GPM)	Dimension "A" (end to end) Inches	Dimension "B" (width) Inches	Dimension "C" (height) Inches	Weights (lbs)
0.50	0.14	1.40	25	8.268	6.457	7.047	22.04
1.00	0.40	4.00	80	8.268	6.457	7.047	30.81
1.50	1.00	10.00	195	8.268	6.457	7.047	35.27
2.00	1.50	15.00	310	8.268	6.457	7.047	39.68
3.00	4.00	40.00	790	11.204	8.78	9.213	59.52
4.00	6.00	60.00	1230	11.204	8.78	9.213	72.75
5.00	10.00	100.00	1980	13.386	13.661	14.09	99.2
6.00	14.00	140.00	2820	13.386	13.661	14.09	110.23
8.00	25.00	250.00	4975	13.386	13.661	14.09	121.25
10.00	39.00	390.00	7790	18.11	18.583	18.583	220.46
12.00	55.50	555.00	11095	19.291	20.784	20.784	286.6
14.00	76.00	760.00	15250	22.047	22.48	22.48	357.15
16.00	99.50	995.00	19900	24.016	25.472	25.472	429.9
18.00	126.00	1260.00	25200	25.984	27.362	27.362	487.22
20.00	155.50	1555.00	31100	25.984	28.465	28.465	694.46
24.00	220.00	2200.00	44900	31.102	32.992	32.992	826.73

Table 1

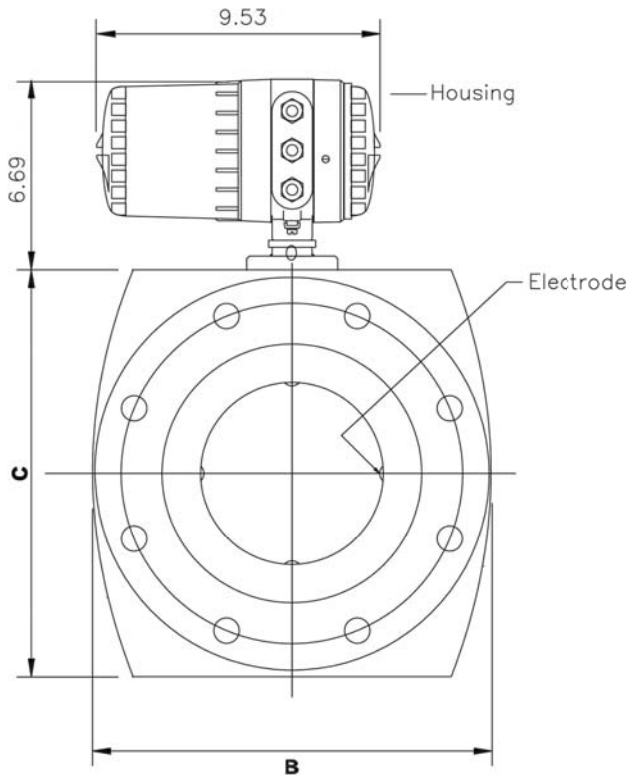

Figure 6

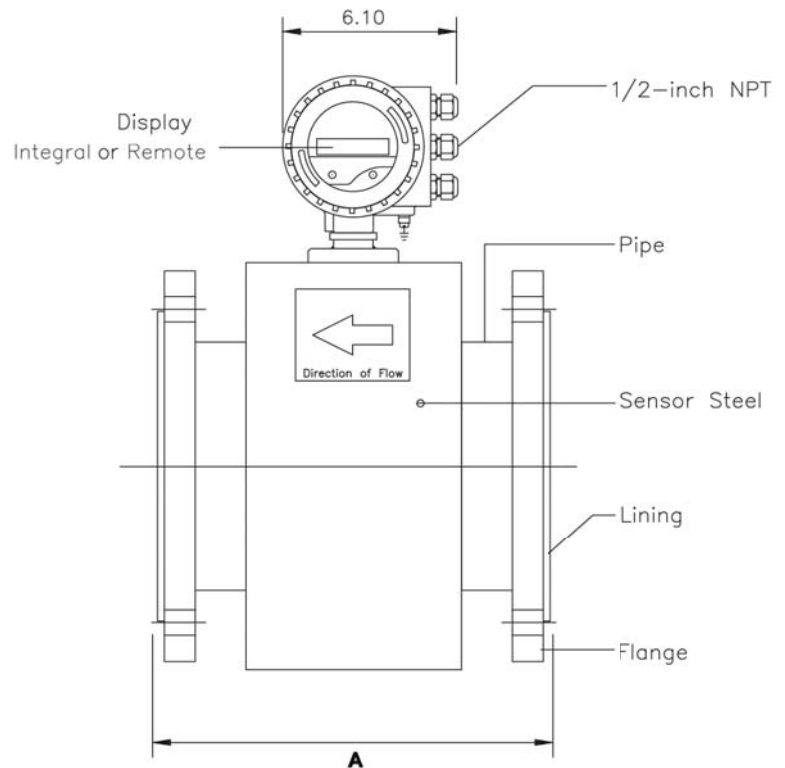

Figure 7



Ordering Information

Please provide completed application data sheet (found at www.aaliant.com) to allow us to confirm selection. For further assistance, please contact our Applications Engineering department at 800-778-9251.

1. Confirm fluid conductivity greater than 5µS/cm.
2. Select meter size to match pipe diameter.
3. Confirm minimum and maximum flow ranges are within your requirements.
4. Confirm suitability of electrodes.
5. Confirm maximum pressure capability of flange/meter rating with process conditions and select flange rating.
6. Confirm suitability of liner materials.
7. Confirm suitability of integral electronics.

Model # 66 - - - - - 000

Line Size	00.5 ½" 01.0 1.0" 01.5 1.5" 02.0 2.0" 03.0 3.0" 04.0 4.0" 05.0 5.0" 06.0 6.0" 08.0 8.0" 10.0 10.0" 12.0 12.0" 14.0 14.0" 16.0 16.0" 18.0 18.0" 20.0 20.0" 24.0 24.0"		
Electrode Material	H Hastelloy C (standard) S 316L Stainless Steel (optional) T Titanium (optional) P Platinum-Rh (optional) M Monel (optional)		
Mounting Connections	0 150# ANSI Flange 1 300# ANSI Flange (½ to 8") 1 300# ANSI Flange Carbon Steel (6.0" - 8.0") 2 150# ANSI Flange Stainless Steel (0.5" - 4.0") 2 150# ANSI Flange Stainless Steel (6.0" - 8.0") 2 150# ANSI Flange Stainless Steel (10.0" & above)		
Liner Material	T PTFE (Teflon) 0.5" - 6.0" T PTFE (Teflon) 8.0" - 12.0" R Hard Rubber (Ebonite) (8.0" - 24.0") R Hard Rubber (Ebonite) (3.0" - 6.0")		
Electronics	0 Integral 1 Remote (330ft Max; specify cable length)		
Power	A 90VAC - 265VAC, 50/60 Hz		

©2008 Venture Measurement. 4/08
 All rights reserved. All data subject to change without notice.

NIST Traceable-Certificate of conformance available if requested at time of order.

MAG6600 Rev. D