

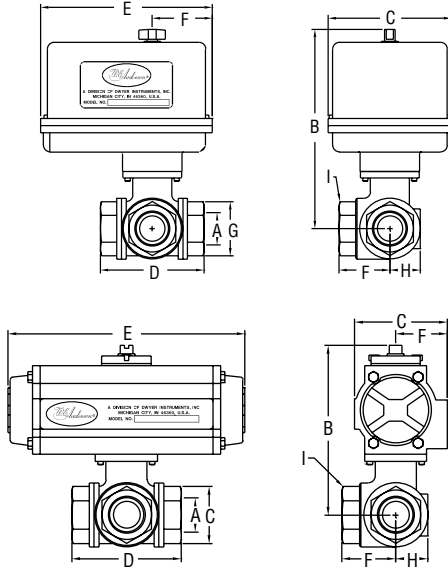

# Series 3ABV Automated Ball Valves - 3-Way Brass NPT

## Specifications - Installation and Operating Instructions



ELECTRIC (NEMA 4 ENCL.) (inches)								
A	1/4"	3/8"	1/2"	3/4"	1"	1-1/4"	1-1/2"	2"
B	5.90	5.90	6.13	6.20	6.57	6.70	6.29	6.82
C	4.00	4.00	4.00	4.00	4.75	4.75	4.75	4.75
D	2.64	2.64	2.64	3.03	3.43	4.13	4.82	5.45
E	5.63	5.63	5.63	5.63	6.88	6.88	6.88	6.88
F	1.43	1.43	1.43	1.59	1.87	2.20	2.44	2.87
G	1.33	1.33	1.33	1.53	1.88	2.36	2.83	3.38
H	0.76	0.76	0.76	0.88	1.00	1.22	1.45	1.75
I	0.86	0.86	1.06	1.25	1.61	1.96	2.16	2.75
ACT.	U11, V11	U11, V11	U11, V11	U11, V11	U12, V12	U12, V12	U12, V12	U13, V13

PNEUMATIC DOUBLE ACTING (inches)								
A	1/4"	3/8"	1/2"	3/4"	1"	1-1/4"	1-1/2"	2"
B	3.96	3.96	3.96	4.30	4.86	5.00	5.94	6.95
C	1.77	1.77	1.77	1.77	2.80	2.80	3.17	3.72
D	2.64	2.64	2.64	3.03	3.43	4.13	4.82	5.45
E	4.33	4.33	4.33	4.33	5.49	5.49	6.38	8.15
F	1.43	1.43	1.43	1.59	1.87	2.20	2.44	2.87
G	1.33	1.33	1.33	1.53	1.88	2.36	2.83	3.38
H	0.76	0.76	0.76	0.88	1.00	1.22	1.45	1.75
I	0.86	0.86	1.06	1.25	1.61	1.96	2.16	2.75
ACT.	DA1	DA1	DA1	DA1	DA2	DA2	DA3	DA4

PNEUMATIC SPRING RETURN (inches)								
A	1/4"	3/8"	1/2"	3/4"	1"	1-1/4"	1-1/2"	2"
B	4.45	4.45	4.45	4.52	5.30	5.44	6.59	7.40
C	2.80	2.80	2.80	2.80	3.17	3.17	3.17	4.17
D	2.64	2.64	2.64	3.03	3.43	4.13	4.82	5.45
E	5.49	5.49	5.49	5.49	6.38	6.38	8.15	9.35
F	1.43	1.43	1.43	1.59	1.87	2.20	2.44	2.87
G	1.33	1.33	1.33	1.53	1.88	2.36	2.83	3.38
H	0.76	0.76	0.76	0.88	1.00	1.22	1.45	1.75
I	0.86	0.86	1.06	1.25	1.61	1.96	2.16	2.75
ACT.	SR2	SR2	SR2	SR2	SR3	SR3	SR4	SR5

The Series 3ABV incorporates a standard port valve for great flow rates with minimal pressure drop. Features include a blowout proof stem for added safety and reinforced TFE seats and seals for longer life and leak-free operation. The four seat design allows for high cyclic capabilities and tight shut-off in any position. Perfect for mixing or diverting services in the food and chemical processing industries. The 3ABV is an economical automated valve package with either an electric or pneumatic actuator. Electrically actuated models are weatherproof, NEMA 4, powered by standard 115 VAC supply, and are available in either two-position or proportional control. Two-position actuators use the 115 VAC input to drive each of the valve ports open or closed, while the modulating actuator accepts a 4-20 mA input for infinite valve positioning. Actuator features include thermal overload protection to withstand stall conditions, visual position indication, and a permanently lubricated gear train. The pneumatic double acting actuator uses an air supply to drive each of the actuator ports. The actuator has two supply ports with one driving the valve stem clockwise, the other for counterclockwise rotation. Spring return pneumatic actuators use the air supply to drive the valve stem in one direction, and internally loaded springs return the valve to its original position. Also available is the SV3 solenoid valve to electrically switch the supply pressure between the air supply ports. Actuators are constructed of anodized aluminum and are epoxy coated for years of corrosion free service.

### SPECIFICATIONS

**Service:** Compatible liquids, gases or steam.  
**Body:** 3-way.  
**Line Size:** 1/4" to 2".  
**End Connections:** Female NPT.  
**Pressure Limits:** 1/4" to 1-1/4": 435 psi (30 bar) WOG, 1-1/2": 232 psi (16 bar) WOG, 2": 145 psi (10 bar) WOG. 100 psi (6.9 bar) SWP.  
**Wetted Materials:**  
 Body, End Cap, Stem: Brass.  
 Ball: Brass, Chrome Plated.  
 Seat, Stem Seal: TFE.  
**Temperature Limits:** 320°F (160°C).  
**Other Materials:** Body Seal, Body O-ring, Stem O-ring: Viton®.

### ACTUATORS

**Electric**  
**Power Requirements:** 120 VAC, 50/60 Hz, single phase. Optional 220 VAC, 24 VAC, 12 VDC, and 24 VDC.  
**Power Consumption:** (Locked Rotor Current): Two Position: 1/4" to 3/4": .55A, 1" to 2": .75A. Modulating: 1/4" to 3/4": .55A, 1" to 2": .75A.  
**Cycle Time:** (per 90°): Two Position: 1/4" to 3/4": 2.5 sec., 1" to 2": 5 sec. Modulating: 1/4" to 3/4": 2.5 sec., 1" to 2": 5 sec.  
**Duty Cycle:** Two Position: 1/4" to 3/4": 75%, 1" to 2": 25%. Modulating: 75%.  
**Enclosure Rating:** NEMA 4. Optional NEMA 7.

**Housing Material:** Aluminum with thermal bonding polyester powder finish.  
**Temperature Limit:** 0 to 150°F (-18 to 65°C).  
**Conduit Connection:** 1/2" female NPT.  
**Modulating Input:** 4 to 20 mA.  
**Standard Features:** Manual override and visual position indicator except modulating units.

### Pneumatic "DA" and "SR" Series

**Type:** DA series is double acting and SR series is spring return (rack and pinion).  
**Normal Supply Pressure:** 80 psi (5.5 bar).  
**Maximum Supply Pressure:** 120 psig (8 bar).  
**Air Connections:** 1/4" female NPT.  
**Air Consumption:** (per stroke) DA1: 2.32 cu. in.; DA2, SR2: 9.34 cu. in.; DA3, SR3: 17.21 cu. in.; DA4, SR4: 20.5 cu. in.; SR5: 39.54 cu. in.  
**Cycle Time:** (per 90°) DA1: .03 sec.; DA2: .04 sec.; DA3: .08 sec.; DA4: .12 sec.; SR2: .09 sec.; SR3: .14 sec.; SR4: .22 sec.; SR5: .33 sec.  
**Housing Material:** Anodized aluminum body and epoxy coated aluminum end caps.  
**Temperature Limit:** -4 to 180°F (-20 to 82°C).  
**Accessory Mounting:** NAMUR standard.  
**Standard Features:** Visual position indicator.

**SERIES 3ABV AUTOMATED BALL VALVES - 3-WAY BRASS**

Size (in.)	Cv		Double Acting Pneumatic	Spring Return Pneumatic	Two Position Electric	Modulating Electric
	L-Port	T-Port	Model*	Model*	Model*	Model*
1/4"	3.26	3.50	3ABV1DA100	3ABV1SR200	3ABV1U1100	3ABV1V1100
3/8"	3.50	4.08	3ABV1DA101	3ABV1SR201	3ABV1U1101	3ABV1V1101
1/2"	4.20	5.02	3ABV1DA102	3ABV1SR202	3ABV1U1102	3ABV1V1102
3/4"	7.00	7.70	3ABV1DA103	3ABV1SR203	3ABV1U1103	3ABV1V1103
1"	12.83	14.24	3ABV1DA204	3ABV1SR304	3ABV1U1204	3ABV1V1204
1-1/4"	18.67	19.72	3ABV1DA205	3ABV1SR305	3ABV1U1205	3ABV1V1205
1-1/2"	29.75	30.69	3ABV1DA306	3ABV1SR406	3ABV1U1206	3ABV1V1206
2"	43.76	44.58	3ABV1DA407	3ABV1SR507	3ABV1U1307	3ABV1V1307

\* Complete model includes **Port Configuration** - see chart below.

Port Configuration	Flow Path	
	Act. Open	Act. Closed
"T" Port	-T1	All Open
	-T2	A-B
	-T3	A-C
	-T4	B-C
"L" Port	-L1	B-C
	-L2	A-B
	-L3	All Closed
		B-C

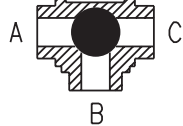

Example: 3ABV1DA204-T2

**ELECTRIC ACTUATOR**

**I. BASIC INSTALLATION**

- Operate valve manually and place in the open position. (NOTE: ALL ELECTRIC ACTUATORS ARE SHIPPED IN THE OPEN POSITION.)
- Remove any mechanical stops the valve might have. (DO NOT REMOVE ANY PARTS NECESSARY FOR THE PROPER OPERATION OF THE VALVE, SUCH AS THE PACKING GLAND, PACKING NUT, ETC.)
- Ensure that the actuator output shaft and valve stem are aligned properly. If they are not, operate the valve manually until they are correct.
- Mount actuator to valve. Do not tighten nuts and bolts at this time.
- Remove actuator cover.
- Bring power to the actuator. CAUTION: Make sure power is OFF at the main box.
- Wire the actuator per the diagram attached to the inside of the cover. Special actuators (those with positioner boards, etc.) will have diagrams enclosed inside the cover.
- Securely tighten bolts used to mount the actuator to a mounting bracket or directly to the valve mounting pad if it is ISO5211 compliant.
- Cycle the unit several times and check the open and closed positions of the valve. Cams are pre-adjusted at the factory; due to the variety of valve designs and types, however, slight adjustments might be required. (SEE II and III).
- Replace cover and tighten screws.

**II. TO SET THE OPEN POSITION**

- Cycle the valve to the open position by applying power to terminals #1 and #2. The top cam and switch control this position. In the open position, the set screw in the top cam will be accessible.
- If the valve is not open completely:
  - Slightly loosen the 8-32 x 1/4" set screw on the top cam.
  - Rotate the cam clockwise (CW) by hand until the switch makes contact. Contact is made when a slight click can be heard. By making incremental CW movements of the top cam, the valve can be positioned precisely in the desired position.
  - When the top cam is set, tighten the set screw securely.
- If the valve opens too far:
  - Apply power to terminals #1 and #3. This will begin to rotate valve CW. When valve is full open and in the exact position desired, remove power from actuator.
  - Loosen the set screw in the top cam.
  - Rotate the top cam counterclockwise (CCW) until the switch arm drops off the round portion of the cam onto the flat section. A slight click can be heard as the switch changes state.
  - Continue applying power to terminals #1 and #3 until valve is in the desired position.

**III. TO SET THE CLOSED POSITION**

- Apply power to terminals #1 and #3 to move the valve toward the closed position. The bottom cam and switch control the closed position. In the closed position, the set screw in the bottom cam will be accessible.

- If the valve is not closed completely:
  - Slightly loosen the 8-32 x 1/4" set screw on the bottom cam.
  - Rotate the cam counter-clockwise (CCW) by hand until the switch makes contact. Contact is made when a slight click can be heard. By making incremental CCW movements of the bottom cam, the valve can be positioned precisely in the desired position.
  - When the top cam is set, tighten the set screw securely.
- If the valve closes too far:
  - Apply power to terminals #1 and #2. This will begin to rotate valve CCW. When valve is fully closed and in the exact position desired, remove power from actuator.
  - Loosen the set screw in the top cam.
  - Rotate the top cam clockwise (CW) until the switch arm drops off the round portion of the cam onto the flat section. A slight click can be heard as the switch is no longer making contact with the round part of the cam.
  - Continue applying power to terminals #1 and #3 until valve is in the desired position.

**IV. MAINTENANCE**

Once the actuator has been properly installed, it requires no maintenance. The gear train has been permanently lubricated and in most cases will never be disturbed. In the event it becomes necessary to open the gear box for any reason, however, Shell Darina #2 grease is recommended for re-lubricating.

**V. DUTY CYCLE**

Most standard electric actuators are rated for 25% duty cycle at 100% ambient temperature at the rated torque.

**VI. THERMAL OVERLOAD**

All actuators are equipped with thermal overload protection to guard the motor against damage due to overheating.

**VII. MECHANICAL OVERLOAD**

All actuators are designed to withstand stall conditions. It is not recommended to subject the unit to repeated stall conditions.

**VIII. SPARE PARTS**

When ordering parts, please specify:  
 A. Model # B. Serial # C. Part Description  
 Recommended spare parts include:  
 A. Standard actuator: set of cams and switches.  
 B. Actuators w/positioner: set of cams and switches; 1K potentiometer; valve positioner board.

**IX. NEMA 7 ELECTRIC ACTUATORS**

In general, operation and maintenance of a NEMA 7 electric actuator is no different than that of a NEMA 4 actuator. However, some precautions must be followed:

- DO NOT under any circumstances remove the cover of the actuator while in a hazardous location. Removal of the cover while in a haz-

- ardous location could cause ignition of hazardous atmospheres.
2. DO NOT under any circumstances use a NEMA 7 electric actuator in a hazardous location that does not meet the specifications for which the actuator was designed.
  3. Always mount and cycle test the actuator on the valve in a non-hazardous location.
  4. When removing the cover, care must be taken not to scratch, scar or deform the flame path of the cover and base of the actuator, since this will negate the NEMA rating of the enclosure.
  5. When replacing the cover on actuators rated for both NEMA 4 & 7, take care that the gasket is in place to assure proper clearance after the cover is secured. After the cover screws are tightened, the clearance between the cover and the base should be checked. A .002" thick by 1/2" wide feeler gauge is used for this; it must not enter between the two mating faces more than .125".
  6. All electrical connections must be in accordance with the specifications for which the unit is being used.
  7. Should the unit ever require maintenance, remove from the hazardous location before attempting to work on the unit.
- If the actuator is in a critical application, it is advisable to have a stand-by unit in stock.

**XI. TROUBLESHOOTING**

SYMPTOM	PROBLEM	SOLUTION
Actuator does not respond to control signal	<ul style="list-style-type: none"> <li>•Power is not on</li> <li>•Actuator wired incorrectly</li> <li>•Incorrect voltage</li> <li>•Thermal Overload</li> <li>•Actuator and Valve in opposite positions when actuator installed</li> </ul>	<ul style="list-style-type: none"> <li>•Turn on Power</li> <li>•Check wiring diagram; re-wire</li> <li>•Bring correct supply to actuator</li> <li>•Allow motor to cool; resets automatically</li> <li>•Remove actuator; remount after 90° turn</li> </ul>
Actuator will not open and/or close completely	<ul style="list-style-type: none"> <li>•Travel limit switch set incorrectly</li> <li>•Valve torque too high</li> <li>•Mechanical stops not removed when installing actuator</li> </ul>	<ul style="list-style-type: none"> <li>•Set cams per instructions</li> <li>•Install correct unit</li> <li>•Remove stops</li> </ul>
Valve oscillates	<ul style="list-style-type: none"> <li>•Torque of valve too high</li> <li>•Actuator without brake installed on butterfly valve</li> <li>•Motor brake misadjusted</li> </ul>	<ul style="list-style-type: none"> <li>•Torque of valve too high</li> <li>•Install brake</li> <li>•Adjust brake; tighten screw</li> </ul>
Actuator motor runs but output shaft does not rotate	<ul style="list-style-type: none"> <li>•Gear damaged/sheared pin</li> </ul>	<ul style="list-style-type: none"> <li>•Contact factory</li> </ul>

**PNEUMATIC ACTUATOR**

**PNEUMATIC ACTUATOR**

**NOTE:** For optimal operation, 3ABV actuators should be run with a supply of clean, lubricated air.

**SPRING RETURN ACTUATORS**

Air to PORT 2 (the right hand port) causes the actuator to turn CCW. Loss of air to PORT 2 causes air to exhaust and the actuator turns CW. This is the FAIL CLOSE operation.

**DOUBLE ACTING ACTUATORS**

Air to PORT 2 (the right hand port) causes the actuator to turn CCW. Air to PORT 1 (the left hand port) causes the actuator to turn CW.

**DISASSEMBLING STANDARD ACTUATORS**

**IMPORTANT:** Before beginning disassembly, ensure that the air supply to the actuator has been disconnected, all accessories have been removed and that the actuator has been dismantled from the valve.

1. Loosen the end cap fasteners (22) with a wrench (size varies depending on actuator model). On the spring return actuator, alternate 3 to 5 turns on each fastener until the springs are completely decompressed. Use caution in removing the cap since the springs are under load until the fasteners are fully extended.
2. Remove the pinion snap ring (10) with a lock ring tool. The indicator (7) may now be removed.
3. Turn the pinion shaft (2) CCW until the pistons are at the full end of travel. Disengage the pistons (11) from the pinion. (NOTE: Low pressure air--3 to 5 P.S.I. MAXIMUM--might be required to force the pistons completely from the body.) Note the position of the pistons before removing them from the actuator body. The part numbers of the pistons are located on the side and should be right-side up on an actuator with a standard orientation.
4. Remove the pinion through the bottom of the actuator. The actuator is now completely disassembled. All replacement parts may now be put in. W.E. Anderson recommends that all wear parts (3, 4, 5, 6, 12, 13, 14) be replaced before reassembly.

**REASSEMBLING STANDARD ACTUATORS**

**IMPORTANT:** Be sure that the actuator surfaces are free of grit and scratches before reassembling.

1. Apply a light film of grease to all o-rings and the pinion before replacing.
2. Put the pinion (2) back through the actuator with the flats of the pinion shaft running parallel with the body.
3. When reassembling the actuator, make sure that the piston racks are square to the actuator body and returned to their original orientation. (NOTE: The normal operation of all BV pneumatic actuators is FAIL CLOSED. To change the orientation to FAIL OPEN, rotate the racks 180° to create a reverse operation.)
4. When replacing springs in a spring return actuator, ensure that the springs are replaced in their identical position in the end cap from which they were removed. (NOTE: In some circumstances, you might want to change the standard 80 pound spring set to fit your application and available air pressure. Changing the spring sets on BV pneumatic actuators requires no special tools. Please refer to the spring combination torque chart in our catalog for the inner and outer spring combinations that will allow you to operate with the spring set that you desire.)
4. Seal the end caps with a petroleum lubricant and bolt to actuator body.
5. Check the seal of the actuator by covering seal areas (pinion, end caps) with soapy water and using low pressure air to the actuator to ensure that no bubbles are produced.

**PNEUMATIC ACTUATOR PARTS LIST**

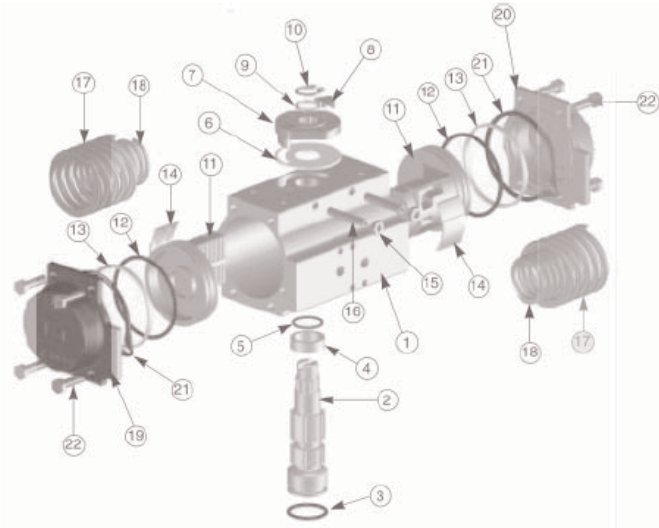

- |  |   |
|--|---|
| 1. Extruded aluminum housing               | 12. Piston O-ring bushing <sup>∅</sup>    |
| 2. Nickel plated steel anti-blowout pinion | 13. PTFE antifriction ring <sup>∅</sup>   |
| 3. NBR 70 lower pinion O-ring <sup>∅</sup> | 14. PTFE piston thrust block <sup>∅</sup> |
| 4. PTFE pinion spacer ring <sup>∅</sup>    | 15. SS stop bolt retaining nut            |
| 5. NBR 70 top pinion O-ring <sup>∅</sup>   | 16. SS stop bolt                          |
| 6. PTFE cam spacer ring <sup>∅</sup>       | 17. External spring*                      |
| 7. SS indicator cam                        | 18. Internal spring*                      |
| 8. Nylon position indicator                | 19. Die cast aluminum end cap (left)      |
| 9. SS pinion washer                        | 20. Die cast aluminum end cap (right)     |
| 10. Pinion snap ring                       | 21. NBR end cap seats                     |
| 11. Die cast aluminum piston               | 22. SS end cap bolt                       |

*\*spring return actuators only*

*<sup>∅</sup>parts subject to wear. Please contact the factory or your W.E. Anderson distributor for replacement kits.*

**MAINTENANCE**

The Series 3ABV Automated Ball Valves are not field serviceable and should be returned if repair is needed (field repair should not be attempted and may void warranty). Be sure to include a brief description of the problem plus any relevant application notes. Contact customer service to receive a return goods authorization number before shipping.

*Viton® is a registered trademark of E.I. du Pont de Nemours and Company.*